

Chapter 1 –Overview

1.0 Introduction

Major areas of concern in the power distribution sector are high AT&C loss and poor power distribution reliability. To address these problems, accurate measurement, diagnosis and remedial action is essential.

The reliability of power is measured in the terms of SAIFI and SAIDI which requires solution based on real time. The system shall be equipped to monitor and help utility to measure SAIFI/SAIDI and facilitate to achieve improvement in the trajectory

Definition

The SAIFI is System Average Interruption frequency Index =
No of customer interruption / Total no of consumers served

The SAIDI is System Average Interruption Duration Index =
No of customer interruption duration/ Total no of consumers served

Objective

To accurately measure reliability of power distribution network and facilitate utility to take suitable administrative action for enhancement of power reliability.

The measurement of reliability shall be ensured by a real time data acquisition system (RT-DAS) using FRTU at S/S. It shall also facilitate Utility to take appropriate measures for improvement of SAIDI/SAIFI by knowing the reason of poor values of indices. SAIFI/SAIDI report for 11KV /22KV feeder, S/S and town measurement shall be generated

Reason 1 Planned

CB operated without fault (Load shedding , Maintenance may be the reason)

Reason 2 Unplanned

Fault driven outage (Overcurrent or Earth fault may be the reason)

Inputs required

- Measurement of :
 - Breaker position
 - Fault relays (O/C , E/F)
 - Analog data (P,Q,V,F,I)
 - No voltage relay at incomers

1.1 Broad Scope

- RT-DAS at Datacentre
- FRTUs at S/S
- Accurate real time system of measurement
- Rugged and robust to withstand in S/S HV environment
- Essential compliance to IEC standards for EMI/EMC and environmental requirement

- Essential compliance to IEC101/104 protocols for communication with FRTU and Modbus with Multi-Function Transducers (MFT)
- Cyber security/security compliance
- GPS Time synchronisation
- SLD and mimics for monitoring at S/S and Data centre
- Notifying S/S about outage through SMS (can be extended to consumers using IT system SMS gateway)
- Reports (SAIFI /SAIDI reports as per regulator defined criteria and as per IEEE norms etc.)
- Operation monitor for switching devices to have preventive maintenance
- Historical data, MIS and analytics
- Future compatibility with SCADA / AMI etc

Schematics for improving SAIFI & SAIDI

IPDS RT-DAS

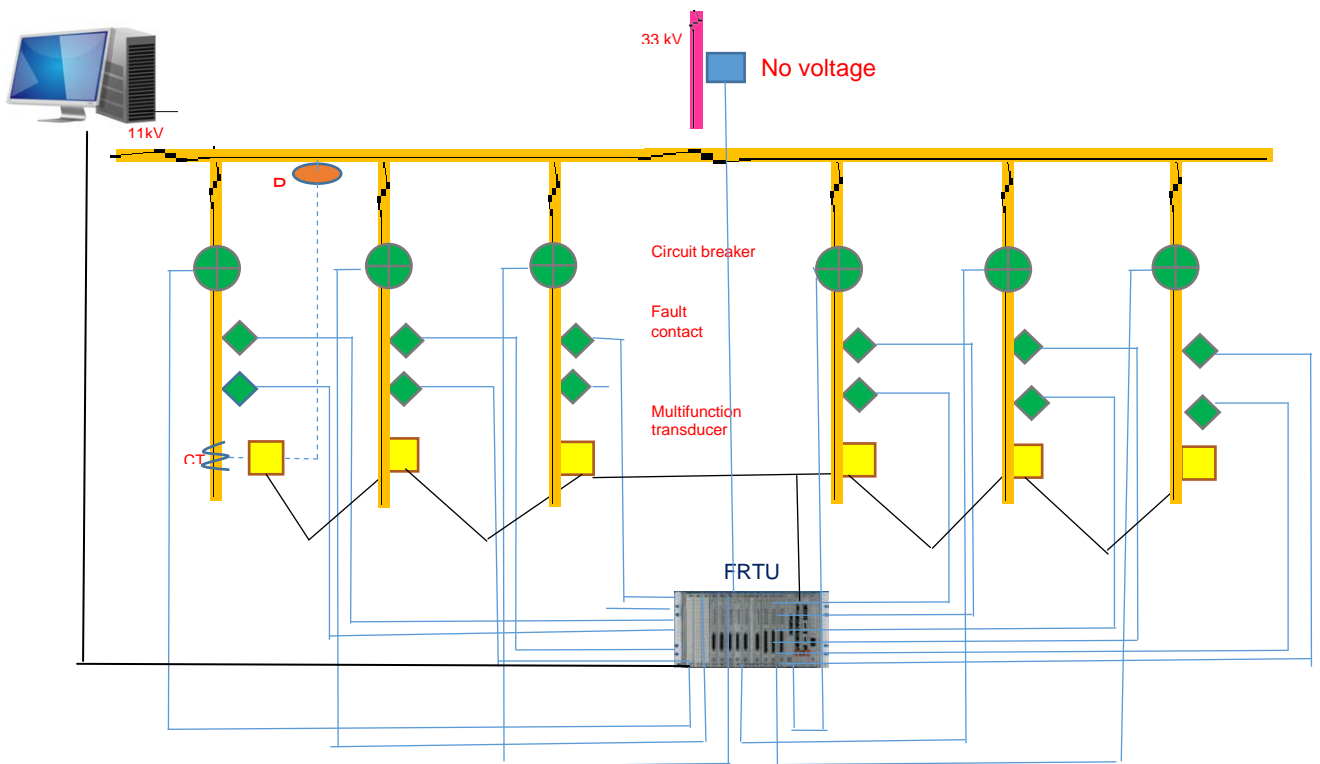

R-APDRP RT-DAS
Data Flow RT - DAS

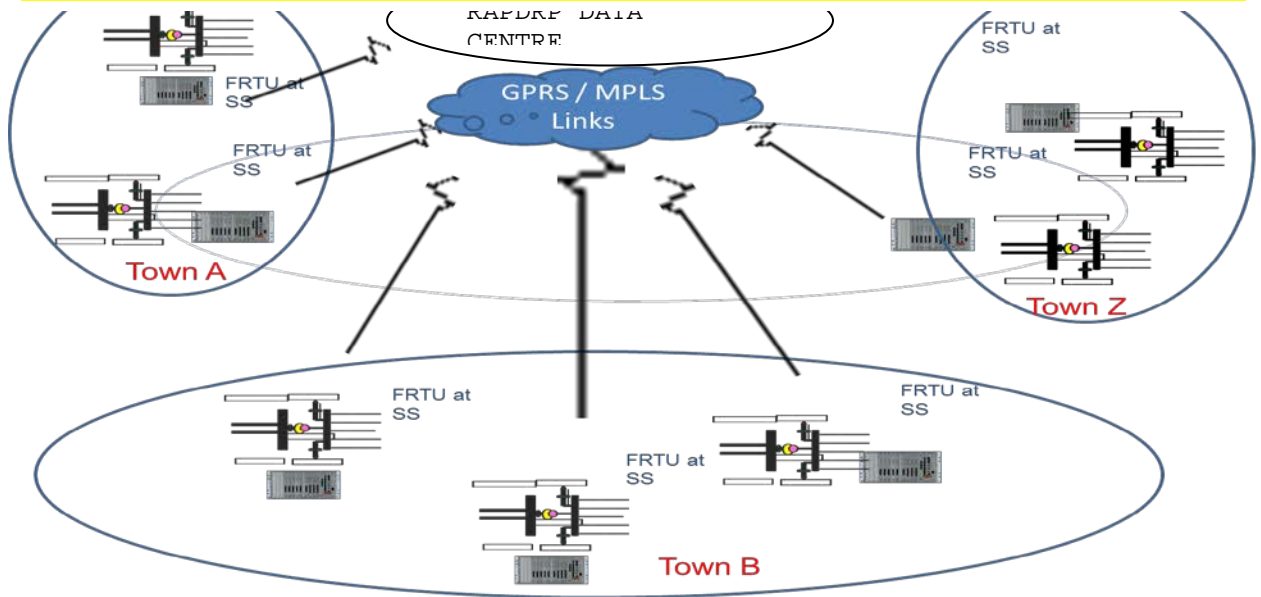

RT-DAS at Data Centre

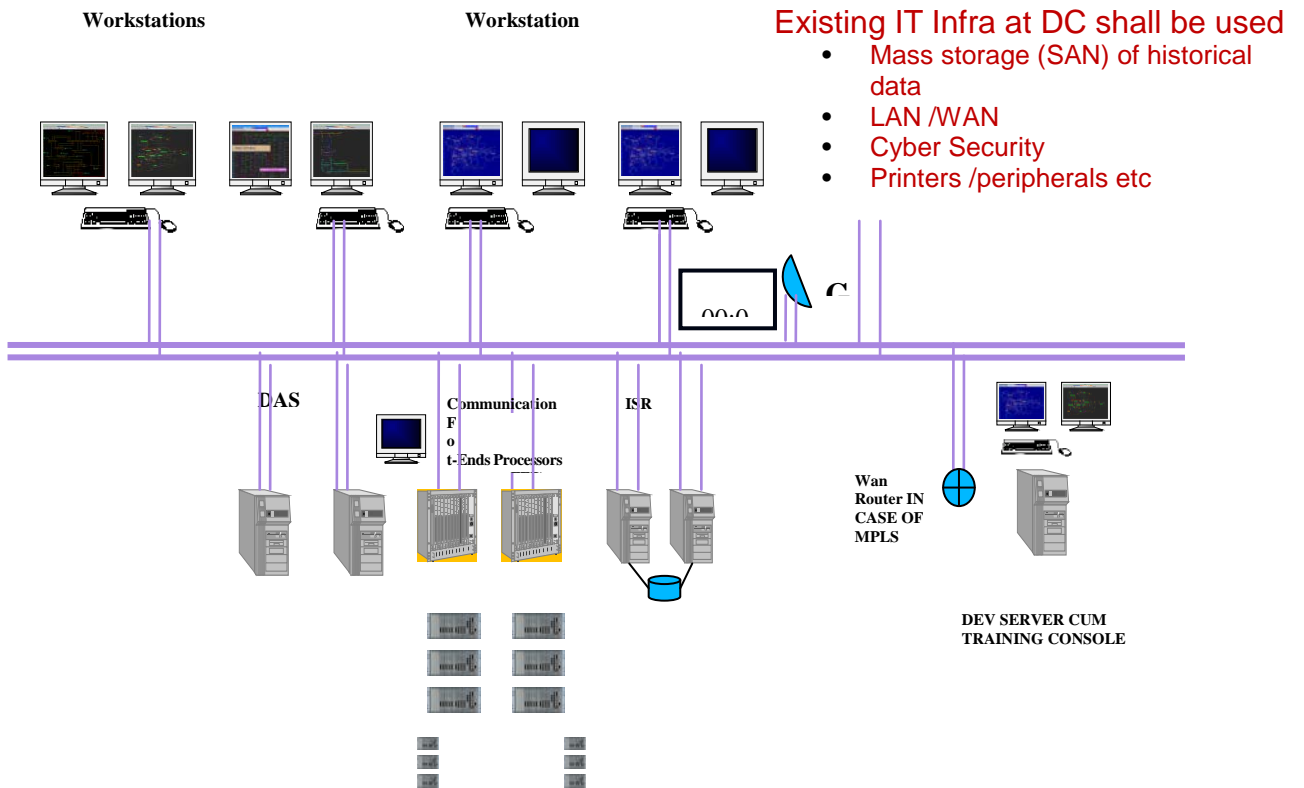

The focus of the system shall be on actual, demonstrable performance in terms of measurement & establishment of reliable and automated systems for measurement of SAIDI and SAIFI.

1.2 Eligibility criteria

- Non SCADA Urban towns of R-APDRP/IPDS

Existing and ongoing work for SAIFI/SAIDI measurement shall not be considered

Union Territory & towns operated by private DISCOMs or distribution franchisee are excluded

1.3 **Responsibility of SSIA**

1.3.1 **The executing agency shall be called as SSIA - (SAIFI SAIDI system Implementation Agency)**

a) **System Design and Engineering**

b) Manufacture, inspection at manufacturer's works, supply, transportation, insurance, delivery at site, unloading, storage, complete supervision, installation and successful commissioning of all the equipment, systems and application software SSIA should furnish at least 5 years warranty along with supporting plan and availability of spares.

c) Any item though not specifically mentioned, but is required to complete the project works in all respects for its safe, reliable, efficient and trouble free operation & to meet performance ,availability & functional requirements as envisaged in the model specification shall also be considered to be included, and the same shall be supplied and installed by the SSIA without any extra cost

d) **Testing and Commissioning including** planning (includes preparing test plans and defining roles and their responsibilities), preparation (consists of preparing test specification, test environment and test data) for all tests viz. Type tests, FAT, SAT and successful commissioning

e) **Integration Scope:** SSIA should ensure that legacy systems and the new solutions supplied by them are tightly integrated and do not remain stand-alone and shall perform on real time basis as envisaged in specifications. All required external systems shall be integrated using an integration middleware layer to be supplied by contractor. Utility shall extend necessary support to contractor for integration of the system . The scope of integration of external systems includes, IT systems under R-APDRP, legacy RTU/FRTU , if any for the objective of project. The same is specified below by utility for objective of the project.. If none then it shall be mentioned as"nil"

--

f) **Geographical Scope:** Locations shall be detailed by the utility in the RFP

g) **Training for Employees**

- h) **Project Management and Site Supervision Bidder** shall provide experienced, skilled, knowledgeable and competent personnel for all phases of the project, so as to provide the utility with a high quality system
- i) **Interface Coordination:** The bidder shall identify all interface issues and inform utility to coordinate and exchange all necessary information among concerned agencies.

The detailed technical requirements including Bill of Quantity of the above components is described in subsequent sections of this volume.

The responsibility of the Contractor shall include supplying, laying and termination of the cables, wherever required for:

- a) Acquiring analog data using MFT, transducer, sensor which shall be connected with the primary devices.
- b) Acquiring the digital data for status of field devices, relays in the control room.
- c) Interconnection between Contact Multiplying Relays (CMRs) and FRTUs & field devices (CMRs to be supplied by the contractor as per BOQ),
- d) Power and signal cabling between the supplied equipment & Owner's equipment's.
- e) Any other cabling required for completion of the project.

In addition to the above, following works are also in the scope of the contractor:

- f) Database and display development
- g) Obtaining the statutory clearances required, if any from Ministry of Communication/ Govt Authority . All the charges deposited to aforesaid authority for obtaining statutory clearance will be reimbursed by the owner. The owner will also provide the necessary support if required in getting the clearances
- h) to make provision for import of GIS data in xml format from IT system for creation of database. In case GIS data is not available due to non readiness of GIS/ IT System, then plain xml data shall be populated by SSIA to meet objective of the project.

j) Generic requirements:

The contractor shall undertake detailed site survey immediately after award of the contract of all the sites to access the various requirements such as space, identification of input terminals, and availability of air-conditioning, spare contacts etc for completion of engineering, site installation, testing and commissioning of the project. The type and number of hardware and software elements (Bill of Quantity) within the scope of the project to be supplied for the various sites are identified in the Appendices. The individual functions to be performed by the hardware and software and system sizing criteria are described in the relevant sections. The specification defines requirements on functional basis and does not intend to specify any particular design, make or model etc.. On the other hand certain minimum requirements must be met in accordance with the particular details provided elsewhere in the specification.

The make of equipment, if any mentioned in this Technical specification are indicative only and bidders may be

allowed to supply products of any make of equivalent quality. This specification is neutral on the name of any make and it is up to the Engineer-in-charge/Utility to decide the acceptable make of equipment including relays, fittings etc. based on given technical specifications, past performance, technical suitability and state practices of the equipment in the system.

1.3.2 Owner shall be responsible for :

- (a) Arranging necessary shutdowns and work permits at various sites.
- (b) Providing all the necessary data regarding the Distribution system network.
- (c) Providing storage space at site free of cost wherever available. Special storage needs such as watch and ward services shall be provided by the contractor.
- (d) The existing earthing system at the substations may be utilised for earthing of the offered equipment. However, the contractor shall assess its suitability for the offered equipment and carry out the modifications if required
- (e) Suitable space/Infrastructure for Data Centre , Substations for installation of equipment's in line with RT-DAS system implementation schedule.
- (f) FMS , bandwidth etc or any OPEX cost to be excluded and shall be borne by utility
- (g) All civil & architectural works, internal and external electrification, earthing, special electronic earthing for Server system, Air conditioning and ventilation, fire fighting system and Access control system required for RT-DAS system are outside the scope of the SSIA, however contractor has to indicate the space requirement for data centre Auxiliary power supply & communication equipment, any other specific requirement, power supply requirement including standby supply requirement, so that the utility can provide the same as per bidder's requirement
- (h) Manpower required for managing RT-DAS system
- (i) A.C. input power supply

1.4 Bidder General Requirements

The Bidders are advised to visit sites (at their own expense), prior to the submission of the proposal, and make surveys and assessments as deemed necessary for proposal submission.

The successful bidder (Contractor) is required to visit all sites. The site visits after contract award shall include all necessary surveys to allow the contractor to perform the design and implementation functions.

The existing infrastructure created under R-APDRP shall be used to maximum extent. The following existing infra should be used:

- Security /firewall /Webservers
- Peripherals such as printers
- LAN/WAN equipment to maximum extent
- Mass/SAN storage device

Utility shall extend support of ITIA /Utility and provide required secured access to IT system

After the site/route survey the Contractor shall submit a survey report for all the sites. This report shall include at least the following items, however, the exact format of the report shall be finalized by the contractor with the approval of Employer.

- (a) Proposed layout of Equipment in the existing rooms and buildings.
- (b) Proposed routing of power, earthing, signal cables and patch cords etc.
- (c) Confirmation of adequacy of Space and AC Power supply requirements
- (d) Proposals for new rooms/buildings, if required
- (e) Identification of facility modifications, if required
- (f) Identify all additional items required for interconnection with the existing equipment.
- (g) Requirement of Modification to existing earthing arrangement, if any.

The offered equipment/system must be in successful operation for at least one year as on the date of bid opening. However, the computer hardware shall be of current industry standard models. The Bidder shall be responsive to the technical requirements as set forth in this specification.

To be considered responsive, the Bidder's proposal shall include the following:

1. A detailed project implementation plan and schedule Manpower resources, proposed to be deployed by the Contractor during the execution phase, shall be clearly indicated.
2. Documentary evidence in support of the qualifying requirements specified in the bidding document i.e. RFP shall be submitted along with the bid.
3. Performance certificate for the offered equipment/systems from the user's in line to the requirements mentioned in the bidding documents.
4. The type test certificates for the offered equipments. In case it is not type tested, commitment for same to be conducted during implementation without any additional cost to owner
5. Technical details of the offered equipment/systems.

To assist in understanding the overall requirements of the project, the following items of special interest are listed.

- (a) The database, displays and reports are to be developed by the contractor; however, the contractor shall associate the employer/owner's engineers also during the data base development. The required hardware & software for completion of this activity may be used out of the hardware & software to be supplied under this contract.
- (b) The APIs (Application Program Interfaces) specified/needed are to be supplied. However, source code for customised part shall be the supplied
- (c) data exchange with IT system.

1.5 Site Conditions

The sites are located in the city of The minimum to maximum temperature & relative humidity generally falls between ... to ...°C. & to % respectively. The state is well connected with road, rail and air transport. However, the system/equipment shall be designed as per the environmental conditions mentioned in the relevant section of this specification.

1.6 Applicable Standards

The offered equipment shall conform to the standards mentioned in the specification. In case of any discrepancy between the description given in the specification and the standards the provisions of the technical specification shall be followed. The parameters

not specifically mentioned in this specification shall conform to the standard mentioned in this specification.

Wherever, new standards and revisions are issued during the period of the contract, the Contractor shall comply with such standards, provided there is no additional financial implication to employer/owner.

In the event the Contractor offers to supply material and/or equipment in compliance to any standard other than those listed herein, the Contractor shall include with their proposal, full salient characteristics of the new standard for comparison.

1.7 Warranty

This would include five years warranty for the related hardware & software supplied under the RT-DAS project after the operational acceptance of equipment at Data centre / Go Live of FRTU at S/S . The five year warranty shall include comprehensive OEM on-site warranty for all components (H/W and Software including OS) supplied including reloading and reconfiguration of all Software and device drivers/patches etc. if required.

CHAPTER -2

RT-DAS FUNCTIONS

2.0 Design requirements

The software shall be modular in nature. The software shall be able to on minimum 64 bit architecture. All the variable parameters of RT-DAS applications, which require adjustment from time-to-time, shall be defined in the database and shall be adjustable by system personnel. All periodicities and time intervals contained in the Specification that define these parameters shall be considered as initial values to be used for performance purposes. The adjustments made to parameters by the user or programmer shall become effective without having to reassemble or recompile programs or regenerate all or portions of the database.

2.1 Function Access

Various application functions shall be designated as single user/ multi-user. For a single-user function, the user with access to the function must relinquish access to it before access can be granted to another user. For a multi-user function any number of users, up to the maximum designated for the function, may have access to the function simultaneously. All such actions shall be recorded as events in the event log

2.2 Critical & non critical functions

The functions defined in this specification shall be classified as Critical or as Non-critical. Every critical function must be supported by sufficient hardware & software redundancy to ensure that no single hardware & software failure will interrupt the availability of the functions for a period exceeding the automatic transfer time defined in the specification.

Non-critical function may not be supported by hardware & software redundancy and can be suspended in case of non-availability of corresponding hardware.

Generally the following are classified as Critical functions

- a) All RT-DAS applications
- b) Information Storage and Retrieval (ISR)
- c) Data exchange among the contractor supplied IT system established under R-APDRP
- d) Web server applications , Security applications

2.3 RT-DAS Functions

The following RT-DAS functions are envisaged under this specification.

- Data Acquisition from FRTUs at S/S
- Time synchronization of FRTUs
- Data Exchange with IT system
- Data Processing
- Sequence of event processing

- Failsoft capability
- Remote database downloading ,diagnostics & configuration
- to make provision for import of GIS data in xml format from IT system for creation of database
- Information Storage & Retrieval (ISR)
- Enterprise SOA Based BUS)

The RT-DAS shall have capability to accept data from the following sources:

- (a) Telemetered data received from FRTUs
- (b) Data exchange
- (d) Calculated data
- (e) Pseudo-data (Manually entered data)
- (f) Import of GIS data in xml format from IT system for creation of database

All input data and parameters, whether collected automatically or entered by an user, shall be checked for validation as per defined logic.

Communication protocol.

RT-DAS system shall use the following protocols to communicate

- a) for FRTU- IEC 870-5-101 /104 protocol
- b) for MFTs – MODBUS
- c) Protocol for IED communication , if any specified in the bid

2.3.1 Data Acquisition

RT-DAS system shall acquire data from Feeder Remote Terminal Units (FRTUs) installed one Number at each S/S

The type of data to be acquired through FRTUs shall include analog values, digital status data (single point indications) and SOE data from the substation.

Analog values like P, Q, F, each phase V, each phase I, each phase pf, and energy values (Export/Import KWh and KVARh) shall be collected by the FRTUs from the MFTs . (if specified in the bid)

The actual point counts & type of data requirement shall be specified

2.3.1.1 Polling method

Digital status data from FRTU shall be collected by RT-DAS system. Digital status data shall have higher priority than the Analog data. The system shall have dead band for data by exception and integrity scan .

The time skew at RT-DAS ,S/S shall not be more than 0.1sec at each location & latency shall not be more than 0.5sec for status. For analog data the time skew shall not be more than 1sec & latency shall not be more than 1sec as per IEEE C37.1.

The contractor must assess & take the network delay into consideration while designing the system so that the update time in normal & peak level of activities are met.

The RT-DAS system shall also be able to collect any and all analog & digital data from its FRTU on demand. Apart from the periodic integrity scan, the integrity scan shall also be initiated automatically for the following situations:

- i. Upon start up of the system
- ii. FRTU status change is detected such as FRTU restart, Communication Link restoration
- iii. On demand by RT-DAS
- iv. On request by the user

The TCP/IP Communication for FRTU on public network shall be encrypted over SSL Security / VPN .The FRTU , all TCP/IP devices that are on Public Network shall form a private VPN network with the Front End, through which encrypted data gets exchanged.

2.3.1.2 Telemetry Failure

If data is not received from an FRTU after a user-adjustable number of retries, each affected point in the RT-DAS system shall be marked with a '**telemetry failure quality code**' and an alarm shall be generated. Telemetry failure of data can be due to failure of communication link, failure of FRTU or FRTU module or MFT etc. Only a single alarm shall be generated if an entire FRTU or its communication channel fails.

In the event of telemetry failure, the last good value/status shall be retained in the database for each affected point. When telemetry returns to normal, the associated RT-DAS system shall automatically resume updating the database with the scanned data.

The user shall be able to substitute a value in the database for any point that is experiencing telemetry failure which shall be marked with '**manual replaced quality code**' in addition to the '**telemetry failure quality code**'. The user shall also be able to delete any point (or entire FRTU) from scan processing. All deleted points shall be marked with a '**delete-from-scan quality code**'.

2.3.2 Time synchronisation of FRTUs

The RT-DAS system will be synchronised from the GPS based Time and frequency system. The system shall synchronise the time of all connected FRTUs every 15 minutes (user configurable from 5 minutes to 24 hrs) using time synchronisation message in the IEC 870-5-104/101 protocol /NTP/SNTP. The servers /Workstations at RT-DAS at Data centre shall be synchronised using NTP/SNTP .

2.3.3 Data Exchange

- Import of GIS data in xml format from IT system for creation of database
- Import Consumers Count tagged to each feeder
- Feeder / S/S/ Town /DISCOM & State wise SAIDI/SAIFI report with IT system

In case of import data is not available from IT system, then contractor shall populate the database on their own without additional cost to mitigate the delay in the project .

Further, system have capability to input , change in consumers count for each feeder in case of difficulty in importing from RAPDRP data center

2.3.4 Data Processing

Data processing involves a value which has been converted to internal form and analyzed for violations of limits. The data processing shall set various data attributes depending on the results of the checks and shall trigger any additional processing or calculation. The RT-DAS system shall prepare all the acquired data for use by the power system applications. The RT-DAS system shall have capability to accept data from the following sources:

- (a) Real-time
- (b) Calculated data
- (c) Manually entered data
- (d) Sequence of events data

2.3.4.1 Analog Data Processing

Analog data processing shall be performed according to the requirements listed below.

(i) Conversion to Engineering Units

Analog points that are transmitted to RT-DAS system in raw data format shall be converted to engineering units before being stored in the database. This conversion function shall include, as a minimum, the capability to perform the following conversion algorithm:

$$\text{Value} = (A * \text{scanned valued}) + B ,$$

where A and B are programmer-adjustable constants assignable as database attributes on a per point basis. The other features that shall be available are limit monitoring, reasonability limit , sign , gradient feature

2.3.4.2 Digital Input Data processing

Each state of a digital input point shall be associated with the state of an actual device. The number of bits that will be used to define the state of a device is defined in the FRTU Specification. A status point shall be defined by single state point. The following pairs of state names shall be provided as minimum:

- (1) Open/Closed
- (2) Tripped/Closed
- (3) Fault/Normal
- (4) On/Off
- (5) Auto/Manual
- (6) Remote/Local

2.3.4.3 Calculated Data processing

RT-DAS system shall be capable of performing calculations and storing the result in the database as calculated data available for display. The database variables to be used for arguments and the mathematical/statistical/logical functions to be used as operations shall be definable interactively at a console as well as by the programmer using database creation and maintenance procedures.

2.3.4.4 Quality Codes

Quality codes indicate the presence of one or more factors that affect the validity of a data value. All quality codes that apply to a data value shall be maintained in the database for that data value. At least the following data quality codes preferably as the following single letter code shall be provided.

Quality code	Reason
Telemetry Failure (FRTU Link)	Telemetry has failed
Manual Replaced	Manual updation
Delete from Scan (FRTU/point)	User disabled the scan of the of data/point
Calculated	Calculated data
Limit Override	Limits are overridden
Reasonability Limit Exceeded	Value beyond reasonability limit
Alarm Inhibit	Alarm processing is inhibited
Test or maintenance mode	Point is in test /maintenance mode

2.3.5 Sequence-of-Events data

Sequence-of-events (SOE) data shall be chronological listings of 'status change events with time stamp' acquired from FRTUs. The SOE data shall be collected from all FRTU either in normal polling or periodically/on demand . SOE data collection shall have lower priority than normal data acquisition. The SOE data collected from different devices shall be merged for chronological listings and stored for subsequent review. Atleast latest 1000 SOE data shall be available for display. RT-DAS system at data centre shall have 10ms SOE resolution. However, as SOE time stamping is done at FRTU level , the same shall be in line with resolution defined for FRTU. All SOE data collected from all FRTU shall be stored in daily RDBMS database of ISR system.

2.3.5.1 RTDAS language

The RT-DAS system shall have capability to write various programs using IEC 61131-3 language or C/C++ or any non proprietary language . It will facilitate user (programmer) to write various programs/ logics using points defined in the database .

2.3.6 Fail-soft capability

The RT-DAS system shall be able to manage & prevent system from total shutdown / crash etc in the event of system crosses mark of peak loading requirements through graceful de-gradation of non –critical functions & also relaxing periodicity / update rate of display refresh & critical functions by 50%..

2.3.7 Remote database downloading ,diagnostics & configuration:

The RT-DAS system shall be able to download database run diagnostics & create/modify/delete configuration/parameterisation from DATA CENTRTE locations to FRTU using ASDU/ messages of respective protocols or file transfer.

2.3.8 Information Storage and Retrieval

Information Storage and Retrieval (ISR) function shall allow collection of data from real-time RT-DAS system and storing it periodically in a Relational database management system (RDBMS) database as historical information (HI) data. This includes storing of data such as SOE, status data, Analog values, calculated values, Energy values etc. Programmer shall also be able to set storage mode as by exception in place of periodic storage.

2.3.8.1 SAIDI /SAIFI Table

SAIDI/SAIFI table for daily, weekly ,monthly basis and specified query duration based for 11/22KV kv feeders, substation, town, Discom , state shall be generated automatically and maintained indicating planned , unplanned and total value of SAIFI SAIDI . Such daily tables for two months duration shall be stored on auxiliary memory. Tables for the previous day shall be backed up to Mass/SAN storage of IT system by the user at 10PM daily. Further , SAIFI/SAIDI table shall be created as per criteria of IEEE and SERC both.

2.3.8.2 Daily Energy Data table

The daily energy data table shall be generated for storage of daily energy values for 15 minute blocks / one hour blocks of a day & shall be stored for each feeder on daily basis alongwith quality codes. Such daily tables for two months duration shall be stored on auxiliary memory. Tables for the previous day shall be backed up to Mass/SAN storage of IT system by the user at 10PM daily.

2.3.8.3 SOE data table

ISR system shall maintain SOE data table which shall store the SOE data for complete distribution system . Such daily tables for two months duration shall be stored on auxiliary memory. Tables for the previous day shall be backed up to Mass/SAN storage of IT system by the user at 10PM daily.

2.3.8.4 System Message Log Storage and Retrieval

System message log, which shall consist of the chronological listing of the RT-DAS computer system alarm messages, event messages and user messages shall be stored for archival and analysis.

Such daily tables for two months duration shall be stored on auxiliary memory. Tables for the previous day shall be backed up to Mass/SAN storage of IT system by the user at 10PM daily.

CHAPTER –3

User interface Requirements

3.1 General Requirements

All RT-DAS functions shall have common user interface as user interaction shall be performed from Operator Consoles envisaged in this specification. All user interactions shall be from full graphics display. The sizing requirements are given in **the appendices in chapter 9,10**

3.2 System Users

The term "user" is applied to the personnel interacting with the RT-DAS system. These users shall be required to login in one or more of following **user modes**, which include:

- (a) Supervisor Personnel responsible for RT-DAS system administration and management such as assigning the access area to users, creating users etc.
- (b) Engineer Personnel having access to maintenance of database/ displays and responsible for support activities such as post fault analysis , report generation, regular backup of database
- (C.) Programmer Personnel responsible for continuing development and maintenance of the RT-DAS system functions, databases, displays and report formats. Security system

3.3 Function and Data Access Security

Password security shall be provided for access to the RT-DAS system, its operating system, layered products, and other applications. After a user has successfully logged on, access to the RT-DAS functions, displays, reports, and databases shall be restricted by pre-assigned operating jurisdictions.

“Single Sign-On” (SSO) technology be employed (i.e., a user logs on once to the RT-DAS using individually defined user name and password which permits appropriate level of access . Further, the facility should be compatible with enterprise-wide SSO capabilities. Each log-on and log-off shall be reported as an event. Unsuccessful attempts to log-on shall also be reported as events.

3.4 Environment

The user interface for RT-DAS system shall be web enabled.

3.5 Display interactions

Rapid, convenient, and reliable display requests shall be provided using the following methods:

3.5.1 Display Requests

- (a) Selection of a display from a menu display
- (b) Cursor target selection on any menu, graphic, or tabular display
- (c) Selection of an alarm : in this case, it shall call up the one-line display containing the alarm's location,
- (d) Selection of an alarm or event message on a summary display followed by a display request command
- (e) Selection of display by Entering a display name or number
- (f) Forward and reverse paging in a page-based display.
- (g) Selecting a previous display by re-call command.
- (h) Selecting a point of interest from an Overview display for viewing on full screen (such as viewing a SLD of a substation by selecting the Substation node from a Network diagram).
- (i) Selecting function keys or cursor targets dedicated to displays.

3.5.2 Display navigation

Display navigation methods shall provide a consistent approach for moving within a display. The following methods shall be provided:

- (a) Panning with cursor positioning device or scroll bars
- (b) Zooming with cursor positioning device
- (c) Navigation window for rapid movement between portions of a world display
- (d) Rubber-band zooming.
- (e) Tool tip
- (f) Find & locate
- (g) Drag & drop

3.5.3 User Help

User help shall present a list of topics available for reference. The topics shall refer to the RT-DAS user documents. The ability to scroll through the topic's explanatory text shall be supported.

The provided help facility shall also support:

- search mechanism
- navigation links between related topics within the help documents
- select/copy mechanism
- print facilities

3.5.4 Overlapping user access

The ability to queue multiple commands from different consoles shall be provided. In this regard, however, interlocks shall be provided to avoid overlapping user access to certain functions.

3.6 Function Key Usage

Special functions shall be assigned to the 12 function keys on a standard keyboard. With extensions (e.g., Shift, Alt, Esc) this shall result in a minimum of 48 function key actions.

3.7 Trend

Trend shall be a display of series of values of parameters on a time axis. Both graphical trend and tabular trends shall be supported. The attributes of the trend display shall be user configurable. The trend application shall be able to show trends for any measurement type from more than one source, at least from real-time, historical and forecast sources.

3.8 Alarms

Alarms are conditions that require user attention. All alarms shall be presented to the user in a consistent manner. Alarm conditions shall include, but not be limited to, the following:

- (a) Telemetered or calculated value limit violations
- (b) Values returning to normal from a limit violation state
- (c) Protection telemetered
- (d) Data source communication errors resulting in loss of data
- (e) RT-DAS system hardware or software failures.

The user shall be able to change the alarm limits.. When the user selects an item to change its alarm limits, a menu showing the alarm limits currently in use and a data entry field for the revised limits shall appear. All changes to alarm limits shall be subjected to data entry error checking and recorded as events.

An alarm category provides the logical interface that connects an alarm condition to a specific Area of Responsibility (AOR) or operational jurisdiction as defined and accordingly alarm shall be reported to user. Each log-on and log-off shall be reported as an event.

Each alarm shall be assigned to an alarm priority level. Each alarm priority level shall be presented in separate display. For each alarm, it shall be possible for the programmer to independently configure the following actions:

- (a) Audible alarm tone type selection and its enabling/disabling
- (b) Alarm messages to be displayed on an alarm summary
- (c) Alarm message deleted from alarm summary when acknowledged
- (d) Alarm message deleted from alarm summary when return-to-normal alarm occurs
- (e) Alarm message deleted from alarm summary when return-to-normal alarm is acknowledged
- (f) Alarm message deleted by user action.

This assignment shall determine how the alarm will be presented, acknowledged, deleted, and recorded.

3.9 Events

Events are conditions or actions that shall be recorded by the RT-DAS system but do not require user action. Events shall be generated under the following conditions

- (a) User initiated actions
- (b) Conditions detected by application functions that do not require immediate user notification, but should be recorded.

Events shall be recorded in the form of an event message.

3.10 Report Generation

The contractor shall be required to generate the Daily, Weekly, Monthly reports formats for RT-DAS system. The report formats shall be finalised during detailed engineering stage. The user shall be able to schedule periodic generation of reports, direct report to display, print report, and archive report using report-scheduling display. The report scheduling display shall enable entry of the following parameters, with default values provided where appropriate:

- (a) Report name
- (b) Report destination (printer or archiving device)
- (c) Time of the system should produce the report.

3.11 System Configuration Monitoring and Control

The user shall be provided with the capability to review RT-DAS computer system configuration and to control the state of the configuration equipment using displays. The following operations shall be possible:

- (a) Failover of each server
- (b) Monitoring of servers, device, including workstations, FRTUs, status & loading of WAN LANs etc.
- (c) Monitoring of the processor resource, hard disk & LAN/WAN utilization
- (d) Configure & monitor of RT-DAS functions

3.12 Displays

Typical list of displays shown below, however the same may be finalised during detailed engineering stage.

- Substation SLD Displays
- SAIFI SAIDI displays (Feeder, S/S ,Town-wise)
- Substation Tabular Displays
- Alarm Summary Displays
- Event Summary Displays
- Manual Override Summary
- Out-of-Scan Summary
- Alarm Inhibit Summary
- Graphical Trending Summary Displays
- Tabular Trending Summary Displays
- Computer system Configuration and Monitoring Displays
- FRTU Communication Channel Monitoring and Control Display
- Help Displays

Chapter -4 SYSTEM SOFTWARE REQUIREMENTS

4.0 General

This chapter describes the characteristics of system software such as Operating system, RDBMS and support software to be provided by Contractor and the original software supplier. The contractor shall make use of common applications such as security, networking etc created under R-APDRP- IT infrastructure. However, it is necessary that functional, availability & performance aspects are met. Bidder shall assess the adequacy of software specified & if any additional software is required to meet all the requirements of the technical specifications, the same shall also be included in the offer. Any additional item required to meet functional, performance and availability requirement shall be supplied without any additional cost to owner , if not included in the bid.

4.1 Software Standards

All RT-DAS software provided by the Contractor, including the Operating system, RDBMS and support software, shall comply with the industry-accepted software standards developed by national and international organizations,.The Contractor shall commit to meet the "open systems" objective promoted by industry standards groups by using software products that are based on open standards

4.1.1 Design and Coding Standards for RT-DAS applications

All RT-DAS applications shall be maintainable by employer using the supplied software utilities and documentation. The RT-DAS software design and coding standards shall also address the following:

- a) Expansion/ scalability: software shall be dimensioned to accommodate the ultimate size of RT-DAS system envisaged.
- b) Modularity: software shall be modular to minimize the time and complexity involved in making a change to a program
- c) SOA architecture: Software shall conform to SOA.
- d) Enterprise service bus (ESB): ESB based architecture is essential to enable interaction of applications from different product manufacturer , platforms etc.
- e) Portability & Interoperability: The software shall be designed for hardware independence and operation in a network environment that includes dissimilar hardware platforms to the extent possible. The use of system services software shall be built on Open standards

4.2 Operating System

The contractor shall use Unix /Linux / Microsoft Windows™ operating system servers.

4.3 Time and Calendar Maintenance

The RT-DAS system shall maintain Time and date for use by various software applications. The GPS based time receiver shall be used for synchronising the RT-DAS system time. All Servers and Operator workstation clocks shall be synchronised within the accuracy of +/-100 milliseconds. The system shall support communication protocols such as NTP and SNTP. The time and frequency standard unit shall support a common time code output format such as IRIG-B. A surge protection system shall be included to prevent the time and frequency standard equipment from lightning.

4.4 Cyber security

Contractor shall use existing data centre infrastructure including, firewalls, LAN, Mass/SAN storage device & software, NMS for cyber security as per NCIIPC/CERT.IN guidelines. Template for Crisis Management Plan (CMP) is available with CERT.IN dist. Anything additional to meet requirement shall be provisioned in the bid. Any additional item required to meet functional, performance and availability requirement shall be supplied without any additional cost to owner, if not included in the bid. The system (software and hardware) shall have adequate cyber security and shall be verified successfully by CERT.IN empanelled agencies/ NCIIPC

4.4.1 Software Maintenance and Development Tools

4.4.1.1.1 Report Generation Software

The RT-DAS system shall include report generation software to generate new report formats for RT-DAS and edit existing report formats. The user shall be guided in defining the basic parameters of the report, such as the report database linkages as symbolic point names, the report format, the report activation criteria, the report destination (workstation, printer, or text file), and the retention period for the report data.

The user shall be able to construct periodic reports and ad-hoc queries via interactive procedures. The capability to format reports for workstations and printers shall be provided. The user shall be able to specify the presentation format for periodic reports and ad-hoc query reports as alphanumeric display format, graphical display format, or alphanumeric printer format. The user shall be able to specify that processing functions, such as summations and other arithmetic functions, be applied to portions of the report data when the report is processed for display, printing, or file storage. The software shall provide for generation of reports that are the full character width of the printers and that use all of the printer's capabilities, such as font sizes and styles and print orientation.

For report data editing, the user shall be able to obtain the data from a retained report, modify the data, repeat the inherent data calculations, reprint the report, and save it in a report retention file on auxiliary memory without destroying the original report.

The user shall also be able to access a retained report, modify its point linkages to the database, modify its format, and save it in a report retention file on auxiliary memory as a new report without destroying the original report.

Executing the report generating functions shall not interfere in any server of the system with the on-line RT-DAS functions.

4.4.1.1.2 System Generation and Build

System generation includes the activity of generating an executable object code of all databases, displays, and reports as required for RT-DAS system. System build is the process under which all the above executables and the executables provided for RT-DAS application software are ported to the RT-DAS system hardware and configuring to make it operational.

The contractor shall do the complete system generation and build as required for successful operation of the RT-DAS system. The contractor shall also provide the complete backup of the RT-DAS system in electronic media such as tapes,

4.4.1.1.3 Diagnostic Utility

The system shall have suitable auto diagnostic feature, on line & offline diagnostic Utility for on-line and off-line monitoring for equipments of RT-DAS system shall be provided.

4.4.1.1.4 System utilisation Monitoring Utility

Software utility shall be provided in each server and workstation to monitor hardware and software resource utilisation continuously and gather statistics.

4.4.1.1.5 Other Utility Services

On line access to user and system manuals for all software/Hardware products (e.g., Operating System and Relational Database Software/hardware) and RT-DAS applications shall be provided with computer system.

Chapter -5

HARDWARE REQUIREMENTS FOR RT-DAS

5.0 Introduction

This chapter articulates the hardware requirements for the RT-DAS system . The conceptual hardware configuration diagram of RT/DAS control centre is indicated in **chapter1**. The bidders are encouraged to optimise the hardware for servers where RT-DAS, FEP & ISR applications can be combined or distributed in any combination with adequate redundancy. However quantity of servers shall be as per detailed bill of quantities for RT-DAS defined in **CHAPTER 8**. Bidder shall assess the adequacy of hardware specified in the BOQ & if any additional hardware is required to meet all the requirements of the technical specifications, the same shall also be included in the offer.

The Bidder shall offer the minimum hardware configuration as specified here for various equipment, however if required, higher end hardware configurations shall be offered to meet all the requirements of the technical specification. The redundant hardware such as servers (Except development server), etc shall work in hot standby manner. IT infrastructure under R-APDRP for LAN/WAN, security & networking hardware shall be used. However, it is necessary to ensure that the functional requirements , availability & performance aspects are met as per RT-DAS specification. Bidder shall assess the adequacy of hardware & if any additional hardware is required to meet all the requirements of the technical specifications, the same shall also be included in the offer.

Any additional item required to meet functional, performance and availability requirement shall be supplied without any additional cost to owner , if not included in the bid.

5.1 General Requirements for Hardware

All hardware shall be manufactured, fabricated, assembled, finished, and documented with workmanship of the highest production quality and shall conform to all applicable quality control standards of the original manufacturer and the Contractor. All hardware components shall be new and suitable for the purposes specified. All hardware such as computers, computer peripherals/accessories etc. and networking products proposed and implemented shall conform to latest products based on industry standard. All hardware shall be of reputed make.

All servers and workstations shall include self-diagnostic features. On interruption of power they shall resume operation when power is restored without corruption of any applications.

The hardware shall be CE/FCC or equivalent international standard compliance . The specification contains minimum hardware requirement. However, the contractor shall provide hardware with configuration equal or above to meet the technical functional & performance requirement . Any hardware /software that is required to meet functional , performance & availability requirement shall be provided by Contractor & the same shall be mentioned in the BOQ at the time of bid . If not mentioned at the time of bid, contractor shall provide the same without any additional cost to the owner

The proposed system shall be designed for an open & scalable configuration, to ensure the inter-compatibility with other systems of the Utility, the future smooth

expansion as well as the easy maintainability. The proposed hardware configuration should be extended by adding either CPU processors / memory boards / disks etc in delivered units or additional units for capacity extension.

The configuration of the RT-DAS shall comprise a distributed computing environment with an open systems architecture. The system architecture shall be open internally and externally to hardware or application software additions, whether supplied by the original supplier of the RT-DAS or obtained from third party vendors, both for capacity expansion and for upgrading functionality, without affecting existing RT-DAS components or operation.

To be recognized as a true open computer system, all internal communications among the RT-DAS Servers and all external communications between the RT-DAS and other computer systems shall be based on widely accepted and published international or industry standards which are appropriate and relevant to the open systems concept or should have a field proven acceptance among utilities. This applies to the operating system, database management system, and display management system, as well as to APIs providing standardized interfacing between System software and application software.

The contractor should ensure that at the time of final approval of hardware configuration/BOQ, all the above hardware are current industry standard models and that the equipment manufacturer has not established a date for termination of its production for said products. Contractor should also ensure that end of life and end of support for all the hardware supplied are at least 7 years beyond date of supply. Any hardware changes proposed after contract agreements shall be subject to the following: -

- a) Such changes/updates shall be proposed and approval obtained from Employer alongwith the approval of Drawings/documents.
- b) The proposed equipment shall be equivalent or with better features than the equipment offered in the Contract.
- c) Complete justification alongwith a comparative statement showing the original and the proposed hardware features/parameters including technical brochures shall be submitted to the Employer for review and approval.
- d) Changes/updates proposed will be at no additional cost to the Employer.
- e) Changes/updates proposed due to end of life / OEM gone out of business / long delivery period etc. , but are not for any commercial benefit of contractor

5.2 Hardware Configuration

In this technical specification all hardware has been broadly classified as server and Peripheral device. The term "server" is defined as any general-purpose computing facility used for hosting RT-DAS, FEP & ISR application functions as defined in the specification. The servers typically serve as the centralized source of data, displays and reports. Peripheral device includes Operator Workstations,

WAN router, LAN, Printer, Time and Frequency synchronisation system, FRTU etc.

5.2.1 Servers

The OEM of servers shall be member of TPC/SPECMARK . can be broadly classified into the following categories:

- RT-DAS
- ISR
- FEP

The minimum hardware configuration of the servers along with TPC / Spec benchmark rating shall be specified by Utility as below. (Utility may specify specification and bidder may provide hardware as per current industry trend subject to meeting functional, performance and availability requirements of the project /specification):

--

Contractor may provide blade or rack mounted servers.

The redundant FEP server shall be a functional unit that offloads the task of communication & pre processing between FRTUS & RT-DAS servers. All FRTU shall be connected to CFE through IEC 60870-5-104/101 link.. For any existing FRTU that are to be integrated, interface must be available to use existing protocols. Free slots shall be made available inside the FEP server, so as additional communication boards can be plugged-in to meet the network future expansion. Each channel shall be assigned a different protocol and the front-end shall be able to manage several protocols in parallel.

The redundancy of front-end servers shall allow handling of FRTUs connected either through single channel or redundant channels. In both cases, one FEP server shall be able to take control of all FRTUs channels. In order to meet network's expansion behind the full capacity of a pair of FE servers, it shall be possible to connect additional FE servers' pairs to the LANs. Each communication line shall be able to support its own communication protocol. The CFE shall comply VPN / SSL based security for connecting with IEC 60870-5-104 &101 nodes on public networks. Further the nodes and FEP shall be self certified by manufacturers as NERC/CIP compliant or eqv international standard for cyber security to comply with future smart grid requirements.

All FEPs shall not have open ports other than needed for protocol traffic / RT-DAS traffic, and shall have an audit trace of all login attempts / connection attempts. This FEP shall exchange data through secured SSL / VPN and encryption of protocol traffic whether it is a is public network or a dedicated one. The equipment should take control command from designated Master IP address only and no other IP.

All FRTU shall be connected to the RT-DAS at data center.

FRTU Communication Card / Module shall support VPN / SSL Security / Encryption of data coming to it through Public network, and then send over private & secure Utility network to the RT-DAS at datacenter .

The FEP shall be able to process time – stamped data and can be directly connected to GPS device for time synchronization

A non- redundant server to host Developmental applications shall be provided

Workstation consoles for development system shall also be available with single monitor. Operator workstation consists of a console driving single/ dual monitors as defined in the BOQ. The user shall be able to switch the keyboard and cursor-positioning device as a unit between both monitors of console. The minimum hardware configuration of operator workstation and Display monitors shall be defined by Utility as below:



5.2.2 WAN router

Wan router shall be required for data exchange of RAPDRP IT-Data centre and FRTUs

The Routers shall be compatible with Owners existing MPLS based Wide Area

5.2.3 Time and Frequency system

GPS based time facility, using Universal Time Coordination (UTC) source, shall be provided for time synchronization of RT-DAS. The time receiver shall include an offset adjustment to get the local time. It shall have propagation delay compensation to provide an overall accuracy of ± 1.5 microsec. The GPS system shall have dual 10/100/1000Mbps LAN interface. The GPS receiver shall be provided in redundant configuration

The time receiver shall detect the loss of signal from the UTC source, which shall be suitably indicated. Upon loss of signal, the time facility shall revert to its internal time base. The internal time base shall have a stability of 2ppm or better.

The GPS system shall include digital displays for time and date in the format DDD:HH:MM:SS (the hour display shall be in 00 to 23 hour format)

GPS system shall also be used to drive separate time , day & date indicators which shall be wall mounted type. The display for time shall be in the 24-hour, HH:MM:SS format. The display for the day & date shall be xxx format (MON through SUN) & DD:MM:YYYY respectively. .

Contractor shall provide wall mounted type digital display units for time, day, date & frequency indication. The display of frequency shall be in the xx.xx Hz format. The frequency shall be derived from 230V AC supply.

Each digit on the time, day and frequency indicators shall be at least 7.5 cm in height and shall be bright enough for adequate visibility in the control room from a distance of 15 meters.

The offered GPS clock shall also provide at least one 2 MHz (75 ohm interface confirming to ITU-T G.703) synchronization interface to meet the time synchronization requirement of the communication system This interface shall confirm to the requirements specified in ITU-T G.811 for accuracy, jitter, wander etc. Alternatively, a separate GPS clock for synchronization of communication system is also acceptable.

5.2.4 Auxiliary Power Supply for Computer systems

The computer system should be suitable for operation with single-phase, 230 $\pm 10\%$ Vac, 50 $\pm 5.0\%$ Hz power supply.

5.2.5 Environmental Conditions

Equipment to be located in the DATA CENTRE building shall operate over an ambient temperature range of 16°C to 32°C, with a maximum rate of change of 5°C per hour. Relative humidity will be less than 80% non-condensing..

5.2.6 Acoustic Noise Level

The noise level of any equipment located in the control room shall not exceed 60dbA measured at three feet from equipment especially for the printers.

Chapter 6

CONFIGURATION & SYSTEM AVAILABILITY

6.0 General

This chapter describes the requirement of monitoring and managing the RT-DAS system with regard to its configuration and availability under normal conditions and under hardware and software failure conditions.

6.1 System Redundancy

The RT-DAS system envisages some functions as critical functions and others as non-critical functions as defined in Chapters 1 and 2. The critical functions shall have sufficient hardware and software redundancy to take care of hardware or software failure condition whereas non-critical functions may not be provided with hardware and software redundancy.

The redundancy requirement for hardware of RT-DAS system shall be as follows:

- (a) Servers: The servers Except development server
- (b) LAN and device interface: LAN shall be configured as redundant.
- (c) Printers: All Printers shall be non- redundant devices.
- (d) Operator workstations: These shall be configured as non-redundant devices.
- (e) Time and frequency system: The GPS receiver of time and frequency system shall be configured as a redundant device at RT-DAS at Data centre
- (f) WAN Router: The WAN router connected to dual LAN shall have channel redundancy.

Every critical function must be supported by sufficient hardware redundancy to ensure that no single hardware failure will interrupt the availability of the functions for a period exceeding the automatic transfer time.

Non-critical functions are those that support maintenance and development of database, application software No hardware redundancy is envisaged for these functions.

Chapter 7

TECHNICAL REQUIREMENTS OF FRTU

7.0 General

The Feeder Remote Terminal Unit (FRTU) for SAIFI /SAIDI measurement shall be installed at primary substation to acquire data from status input devices of breakers or protection relay viz O/C & E/F , CMRs , Multifunction Transducers (MFTs), discrete transducers for analog data The supplied FRTUs shall be interfaced with the substation equipment, communication equipment, power supply distribution boards; for which all the interface cables, TBs, wires, lugs, glands etc. shall be supplied, installed & terminated by the Contractor.

7.1 Design Standards

The RTUs shall be designed in accordance with applicable International Electro-technical Commission (IEC), Institute of Electrical and Electronics Engineer (IEEE), American National Standards Institute (ANSI), and National Equipment Manufacturers association (NEMA) standards, unless otherwise specified in this Technical specification. In all cases the provisions of the latest edition or revision of the applicable standards in effect shall apply. The FRTU shall be designed around microprocessor technology. For easy maintenance the architecture shall support pluggable modules on backplane. The field wiring shall be terminated such that these are easily detachable from the I/O module.

7.2 FRTU Functions

All functions described herein shall be provided by the Contractor even if a function is not initially implemented.

As a minimum, the FRTU shall be capable of performing the following functions:

- (a) Acquiring analog values from Multifunction Transducers or alternatively through transducer- less modules (Usage of current loops 4-20Ma standard signals such as 0-5vdc etc) , transducer etc
- (b) Status inputs of devices from the substation, processing and transmitting to Master stations.
- (b) Data transmission rates - 300 to 19200 bps for Serial ports for MODBUS. /10/100 mbps for TCP/IP Ethernet ports
- (d) IEC 60870-5-104 protocol to communicate with the Master station(s), IEC 60870-5-101 for slave devices. & MODBUS protocol over RS485 interface, to communicate with the MFTs.
- (e) Automatic start-up and initialisation following restoration of power after an outage without need of manual intervention. All restarts shall be reported to the connected master stations.
Remote database downloading of FRTU from master stations
- (f) Act as data concentrator on IEC60870-5-101/104/MODBUS protocols

- (g) Internal battery backup to hold data in SOE buffer memory & also maintaining the time & date.
- (h) As the \ system will use public domain such GPRS/3g/4g etc, therefore it mandatory to guard the data/ equipment from intrusion/damage/breach of security & shall have SSL/VPN based security.
- (i) Shall have SNMP

Support Feature:

All support feature as mentioned below will not be used now & may require in future . However, the same shall be tested in routine /Factory Tests. Further, it should be possible to have following capabilities in the FRTU by way of addition of required hardware limited to addition of I/O modules & communication card only & using the same firmware at later date:

Receiving and processing digital commands from the master station(s)

7.3 Communication ports

- FRTU shall have two TCP/IP Ethernet ports for communication with Master station(s) using IEC 60870-5-104.
- FRTU shall have required number of RS 485 ports for communication with MFTs to be connected in daisy chain using MODBUS protocol.
- FRTU shall have one port for connecting the portable configuration and maintenance tool for FRTU.
- SSL/VPN ,NERC/CIP compliant or equivalent international standards

It shall be possible to increase the number of communication ports in the FRTU by addition of cards, if required in future

7.3.1 Master Station Communication Protocol

FRTU shall use IEC 60870-5-104 communication protocol for communicating to master station. The FRTU communication protocol shall be configured to report analog (except energy values) & status changes by exception to master stations. However, RTU shall support periodic reporting of analog data and periodicity shall be configurable from 2 sec to 1 hour. Digital status data shall have higher priority than the Analog data. The feature of dead-band for reporting Analog value by exception shall be possible. All the analog values and status data shall also be assigned to scan groups for integrity check by Master stations at every 10 minutes configurable up to 60 minutes FRTU wise.

7.4 Analog Inputs

The real time values like, Active power, Reactive Power, Apparent power three phase Current & Voltage and frequency, power factor & accumulated values of import /export energy values will be acquired FRTU from MFTs installed in each 11kv feeder of substations

7.5 Status input

FRTU shall be capable of accepting isolated dry (potential free) contact status inputs. The RTU shall provide necessary sensing voltage, current, optical isolation and de-bounce filtering independently for each status input. The sensing voltage shall not exceed 48Vdc.

FRTU shall be set to capture contact operations of 20 ms or more duration. Operations of less than 20 ms duration shall be considered no change (contact bounce condition). The RTU shall accept two types of status inputs i.e. Single point Status inputs and Double point status inputs.

To take care of status contact chattering, a time period for each point and the allowable number of operations per time period shall be defined. If the allowable number of operations exceed within this time period, the status change shall not be accepted as valid

Single point status input will be from a normally-open (NO) or normally-closed (NC) contact which is represented by 1-bit in the protocol message.

The Double point status input will be from two complementary contacts (one NO and one NC) which is represented by 2-bits in the protocol message. A switching device status is valid only when one contact is closed and the other contact is open. Invalid states shall be reported when both contacts are open or both contacts are closed.

All status inputs shall be scanned by the FRTU from the field at 1 millisecond periodicity.

7.6 Sequence of Events (SOE) feature

To analyse the chronology or sequence of events occurring in the power system, time tagging of data is required which shall be achieved through SOE feature of FRTU. FRTU shall have an internal clock with the stability of 100ppm or better. The FRTU time shall be set from time synchronization messages received from master station using IEC 60870-5- 104 protocol. In addition, the message can be transmitted using NTP/SNTP. SOE time resolution shall be 10ms or better

The FRTU shall maintain a clock and shall time-stamp the digital status data. Any digital status input data point in the FRTU shall be assignable as an SOE point. Each time a SOE status indication point changes the state, the FRTU shall time-tag the change and store in SOE buffer within the FRTU. A minimum of 1000 events can be stored in the SOE buffer. SOE shall be transferred to Master Station as per IEC 60870-5-104 protocol. SOE buffer & time shall be maintained by FRTU on power supply interruption.

7.7 Contact Multiplying Relays (CMRs)

Contact Multiplying Relays (CMRs) are required to multiply the contacts of breaker, isolators and protection relays etc. The contacts of these relays shall be

used to provide status inputs to the FRTUs.

The relays shall be DC operated, self reset type. The rated voltage for relay operation shall be on 24/48/110/220V DC depending on the station DC supply. The relay shall be able to operate for +/-20% variation from nominal voltage.

The relay shall have a minimum of two change over contacts, out of which one shall be used for telemetry purposes. The contacts shall be rated to carry minimum current capacity of 5A.

The relay shall conform to following requirement.

- a) Power Frequency withstand voltage—2KV for 1 minute as per IEC 255-5.
- b) Insulation Resistance of 100M ohms measured using 500V DC megger.
- c) 5KV Impulse test as per IEC 255-5

The relays coils shall be shunted with diodes to suppress inductive transients associated with energizing and de-energizing of the relay coils. The relays shall conform to the IEC 255-1-00 and IEC 255-5 requirements. The relays must be protected against the effects of humidity, corrosion & provide with a dust tight cover. The connecting terminals shall be screw type & legibly marked. The relays may optionally have a visual operation indicator. The relays shall be equipped with suitable mounting arrangements. In case suitable space is not available in C&R panel the same shall be mounted in RTU panel or suitable panels, which shall be supplied & mounted on the top of the C&R panel by the contractor.

7.8 Time facility

The internal RTU time base shall have a stability of 10 ppm. The RTU shall be synchronised through synchronisation message from master station at every 15 minutes (configurable from 15 minutes to 24hrs) over IEC 60870-5-104/101/NTP/SNTP. The RTU shall also carry out time stamping of the events which are not received as time stamped from connected IEDs/MFTs etc.

7.9 Diagnostic Software

Diagnostic Software shall be provided to continuously monitor operation of the FRTU and report FRTU hardware errors to the connected master stations. The software shall check for memory, processor, and input/output ports errors and failures of other functional areas defined in the specification of the RTU.

7.10 Input DC Power Supply

The FRTU will be powered from a 48 V DC power supply system. The FRTU shall not place additional ground on the input power source. The characteristics of the input DC power supply shall be

- (a) Nominal voltage of 48 Vdc with variation between 40.8 and 57.6 Vdc.(i.e. 48(+20%/-15%)
- (b) Maximum AC component of frequency equal to or greater than 100 Hz and 0.012 times the rated voltage peak-to-peak.

The FRTU shall have adequate protection against reversed polarity, over current and under voltage conditions, to prevent the FRTU internal logic from being damaged and becoming unstable causing mal-operation. The specification for DCPS is given in respective section of MTS.

7.11 Environmental Requirements

The FRTU will be installed in control room buildings with no temperature or humidity control. The RTUs shall be capable of operating in ambient temperature from 0 to +55 degree C with rate of temperature change of 20 degree C/hour and relative humidity less than 95%, non-condensing. For FRTUs to be installed in the hilly region with the history of snowfall, the lower ambient temperature limit shall be -5 degree C.

7.12 FRTU Size and Expandability

FRTU shall be equipped for the point counts defined in the BOQ (Basic+20% spare (wired & hardware). It shall be possible to expand the FRTU capability for additional 100 % of the basic point counts by way of addition of hardware such as modules, racks, panels, , however, FRTU software and database shall be sized to accommodate such growth without requiring software or database regeneration.

7.13 FRTU Panels

At least 50% of the space inside each enclosure shall be unused (spare) space that shall be reserved for future use. The Contractor shall provide required panels conforming to IEC 529 for housing the FRTU modules/racks, relays etc. and other required hardware. The panels shall meet the following requirements:

- (a) shall be free-standing, floor mounted and height shall not exceed 1200 mm. All doors and removable panels shall be fitted with long life rubber beading. All non load bearing panels/doors shall be fabricated from minimum 1.6 mm thickness steel sheet and all load bearing panels, frames, top & bottom panels shall be fabricated from minimum 2.0 mm thickness steel sheet
- (b) shall have maintenance access to the hardware and wiring through lockable full height doors.
- (c) shall have the provisions for bottom cable entry
- (d) The safety ground shall be isolated from the signal ground and shall be connected to the ground network. Safety ground shall be a copper bus bar. The contractor shall connect the panel's safety ground of to the owner's grounding network. Signal ground shall be connected to the communication equipment signal ground.
- (e) All panels shall be supplied with 230 Vac, 50 Hz, single-phase switch and 15/5A duplex socket arrangement for maintenance.

- (f) All panels shall be provided with an internal maintenance lamp, space heaters and gaskets.
- (g) All panels shall be indoor, dust-proof with rodent protection, and meet IP41 class of protection.
- (h) There shall be no sharp corners or edges. All edges shall be rounded to prevent injury.
- (i) Document Holder shall be provided inside the cabinet to keep test report, drawing, maintenance register etc.
- (j) All materials used in the enclosures including cable insulation or sheathing, wire troughs, terminal blocks, and enclosure trim shall be made of flame retardant material and shall not produce toxic gasses under fire conditions.

7.14 Wiring/Cabling requirements

The FRTU panels shall gather all signals from and to the devices located in the substation control room. All wires that carry low-level signals shall be adequately protected and separated as far as possible from power wiring. All wires shall be identified either by using ferrules or by colour coding. In addition, cables shall be provided with cable numbers at both ends, attached to the cable itself at the floor plate where it enters the cubicles.

Shielded cables shall be used for external Cabling from the RTU panels. The external cables (except communication cables) shall have the following characteristics:

- a) All cables shall have stranded copper conductor.
- b) Minimum core cross-section of 2.5 mm² for PT cables, 4 mm² for CT cables, if applicable and 2.5 mm² for Control and Status inputs
- c) Rated voltage U₀/U of 0.6/1.1KV
- d) External sheathing of cable shall have oxygen index not less than 29 & temperature index not less than 250. Cable sheath shall meet fire resistance test as per IS 1554 Part- I.
- e) Shielding, longitudinally laid with overlap.
- f) Dielectric withstand 2.5 kV at 50 Hz for 5 minutes
- g) External marking with manufacture's name, type, core quantity, cross-section, and year of manufacture.

Armoured. Cables shall be used in the area where cable will pass through open area which may experience loading.

The Communication cable shall be of shielded twisted pairs and of minimum 0.22sq mm size.

7.15 Terminal Blocks (TBs)

Terminal blocks shall be having provision for disconnection (isolation), with full-depth insulating barriers made from moulded self-extinguishing material. Terminal blocks shall be appropriately sized and rated for the electrical capacity of the circuit and wire used. No more than two wires shall be connected to any terminal. Required number of TBs shall be provided for common shield termination for each cable.

All terminal blocks shall be suitably arranged for easy identification of its usages such as CT circuits, PT circuits, analog inputs, status inputs, control outputs, auxiliary power supply circuits, communication signals etc. TBs for CT circuits shall have feature for CT shorting (on CT side) & disconnection (from load side) to facilitate testing by current injection. Similarly, TBs for PT circuit shall have feature for disconnection to facilitate voltage injection for testing. 10% spare TBs should be provided.

7.16 FRTU Architecture

- a) Centralized FRTU design where all I/O modules are housed in FRTU panels and communicating with master station through communication port.

7.17 MFT Requirements:

All transducers including weather sensor shall use a 48 Vdc auxiliary power supply as provided for the FRTU. Optionally, MFTs can also be self powered. All transducers shall have a maximum power consumption of 10 watts. Transducer shall be din rail or wall/plate mounted.

The input, output and auxiliary circuits shall be isolated from each other and earth ground. The transducer output shall be ungrounded and shall have short circuit and open circuit protection. The transducers shall comply to the following requirements, in addition to the requirement of IEC 60688, without damage to the transducer.

- (a) **Voltage:**

Voltage test and other safety requirement compliance as specified in IEC 60688 or 60687 and IEC 414.

- (b) **Impulse Withstand:**

IEC 60688 or 60687 compliance is required.

- (c) **Electromagnetic Compatibility:**

IEC 60688 or 60687 and IEC 801-3, level 1 compliance is required.

(d) Permanent Overload Protection:

IEC 60688 or 60687 compliance is required.

(e) Temporary Overload Protection:

IEC 60688 or 60687 compliance is required.

(f) High Frequency Disturbance:

IEC 60688 or 60687 compliance is required.

The transducers shall comply with the following general characteristics:

(a) Shock Resistance:

Minimum severity 50 A, IEC 68-2-27 requirements

(b) Vibration Strength:

Minimum severity 55/05, IEC 68-2-6 requirements.

(c) Input Circuit Consumption:

Less than or equal to 0.2 VA for voltage and 0.6VA for current circuits.

(d) Reference Conditions For Accuracy Class:

IEC 60688 or 60687 compliance is required.

(e) Temperature Rise:

IEC 60688 or 60687 compliance is required.

(f) Operating Temperature: 0 °C to + 60 °C (-5 °C to + 55 °C for project area with snowfall history)

The contractor shall provide the multi function transducers for acquiring the real time analog inputs through 3 phase 3 wire CT/PTs circuits/ 3 phase 4 wire CT/PTs circuits (Based on the field requirement). Based on the CT/PT secondary rating , the multi function transducer shall be designed for nominal 110 V (Ph-Ph voltage) and 1A/5A (per phase current). The MFT shall be suitable for 20% continuous over load and shall be able to withstanding 20 times the normal current rating for a period one second. The MFT shall be able to accept the input voltages upto 120% of the nominal voltage. The MFT shall have low VA burden. MFTs shall be mounted in the FRTU panel / interface cabinet to be supplied by the contractor.

Multi function transducers shall provide at least phase voltage, phase current active/reactive power , import & export energy (active & reactive) , pf , frequency

with class 0.5 accuracy or better.

The parameters to be acquired from multifunction transducers shall be selectable. MFT shall provide the 15 minute values (configurable 15 minute/1 hour) of Active Energy Import, Active Energy Export, Reactive Energy Import and Reactive Energy Export.

Multi function transducers shall accept nominal 48 V DC as auxiliary power supply. Optionally, MFT can be self-powered also. Multi function transducer shall be provided with RS485 interface to communicate with RTU over Modbus protocol in multi-drop mode. Optionally, the MFT with IEC60870-5-101/104 can be used.

The MFTs shall be suitable for mounting on DIN rails. The MFT terminals shall accept upto two 2.5 mm² / 4 mm² for PT/CT circuit terminations as applicable.

The MFT shall be programmable with password protection thru suitable facia mounted key pad arrangement so that the configuration parameters such as CT

7.18 TEST EQUIPMENTS FOR FRTU

Test equipment for FRTU shall have Configuration and maintenance tool consisting of the followings:

7.18.1.1 FRTU Data base configuration & Maintenance software tool

The FRTU database configuration & Maintenance software tool shall be required to perform the database modification, configuration, compilation and documentation. The database compiler shall provide error detection services. It shall also perform the downloading of the compiled database into the FRTU database.

7.18.1.2 Master station-cum- FRTU simulator & protocol analyzer software tool

The Master station cum FRTU simulator tool shall be used to test the communication interfaces of Master station, FRTU and Electronic MFT. The Master station simulator tool shall be capable of emulating the master station for IEC 60870-5-104,101 and MODBUS protocols. The FRTU simulator shall be capable of emulating the slave protocols for both the IEC 60870-5-104,101, and MODBUS protocols for MFTs. It shall also be possible to prepare illegal messages for transmission, such as messages having invalid checksum.

The protocol analyser shall be used to monitor all communication traffic on a channel (between Master station & FRTU and between FRTU & MFT without interfering channels operation. Channel traffic captured in the active or passive modes of operation shall be displayed.

The Master station simulator and protocol analyser tool shall also have following features:

- Each received message shall be checked for validity, including the check sum.
- The tool shall maintain and display error counters so that the number of errors during a period of unattended testing can be determined.

- All fields of a message shall be displayed. A pass/fail indication for the message shall be included.

A laptop PC shall be used for the above mentioned software tools. The laptop PC shall be provided with all hardware accessories including cables, connectors etc. required for interfacing with Master station, FRTU and MFT. A suitable Hub shall be provided to use the tool in monitor mode. A carrying case and a suitable power adaptor (input 230VAC, 50Hz) for laptop PC shall also be supplied.

7.19 FRTU Testing

This chapter describes testing, training & documentation requirement for /FRTU

7.19.1 Type Testing:

FRTU including Transducers shall conform to the type tests listed in the relevant table. Type test reports of tests conducted in NABL accredited Labs or internationally accredited labs within last 5years from the date of bid opening may be submitted. In case, the submitted reports are not as per specification, the type tests shall be conducted without any cost implication to employer. A complete integrated unit shall be tested to assure full compliance with the functional and technical requirements of the Specification. The testing sample shall include one of each type of cards/modules and devices. The list of Type tests to be performed on the FRTU is mentioned in **Table-1** & type test requirements are mentioned in **Table-2 of this chapter**. For other items also such as MFT, sensor etc the requirements are mentioned in the respective sub sections of specification.. However, the type tests shall only be limited to the specification of that item only & not as specified for RTU/FRTU.

7.19.2 Routine Testing or Factory acceptance test (FAT):

Each complete unit shall undergo routine testing. The list of Routine tests to be performed in the factory is mentioned in **Table-2**.

7.19.3 Site Acceptance Test (SAT)

7.19.3.1 Field Tests

After FRTU panel installation, interface cabling with field & communication equipment, the Contractor shall carry out the field-testing. The list of field tests for FRTU is mentioned in **Table-2**

7.19.3.2 Availability Tests

After field testing, FRTU shall exhibit a 98% availability during test period. Availability tests shall be performed along with Master station. FRTU - shall be considered available only when all its functionality and hardware is operational. The non-available period due to external factors such as failure of DC power supply, communication link etc., shall be treated as hold-time & availability test duration shall be extended by such hold time.

7.20 TRAINING

The contractor shall provide training to the Employer's personnel. The training program shall be comprehensive and provide for interdisciplinary training on hardware and software. The training program shall be conducted in English. FRTU training course shall cover the following:

- a) FRTU operation including data flow.
- b) Troubleshooting, identification and replacement of faulty Modules.
- c) Preventive maintenance of the FRTU
- d) Use of FRTU configuration and Maintenance tool
- e) All functional and Diagnostic testing of FRTU
- f) Database modification and configuration of FRTU

7.21 DOCUMENTATION

The Contractor shall submit 3 sets of all the standard and customised FRTU documents for review and approval which includes the following:

- a) FRTU Function design document
- b) FRTU Hardware description document & all the documents referred therein to meet all the clauses of the specification.
- c) FRTU Test equipment user documents
- d) FRTU user guide
- e) FRTU Operation & Maintenance document
- f) FRTU Training documentation
- g) FRTU database document
- h) FRTU point list
- i) FRTU Test procedures
- j) Data Requirement Sheet (DRS) of all items
- k) Protocol documentation including implementation profile etc.
- l) FRTU installation and Layout, GA, BOQ, schematics and internal wiring drawings for each FRTU site
- m) FRTU to field device cabling details for each FRTU site

After approval of all the above documents, the Contractor shall submit three sets as final documents. In case some modifications/corrections are carried out at site, the contractor shall again submit as built site-specific drawings in three sets after incorporating all such corrections as noticed during commissioning of the FRTU.

Table-1
List of Tests on FRTU

Test Nos.	DESCRIPTION OF THE TEST	Type test	Routine test	Field test
A	FUNCTIONAL TESTS FOR FRTU			
1.	Check for BOQ, Technical details, Construction & Wiring as per FRTU drawings	√	√	√
2.	Check for database & configuration settings	√	√	√
3.	Check the operation of all Analog inputs, Status input & of FRTU	√	√	√
4.	Check operation of all communication ports of /FRTU	√	√	√
5.	Check for communication with master stations including remote database downloading from master station	√		√
6.	Check for auto restoration of FRTU on DC power recovery after its failure	√		√
7.	Test for self diagnostic feature	√		√
8.	Test for time synchronization from Master	√		√
9.	Test for SOE feature	√		√
10.	End to end test (between FRTU & Master station) for all I/O points			√
11.	Test for MODBUS protocol implemented for acquiring data from-MFT/ transducers and updation time demonstration in daisy chain configuration	√		√
12.	Test for IEC 60870-5 -104,101 protocol implemented	√		√
13.	Test for supporting other protocol	√		
14.	Test for operation with DC power supply voltage variation	√		
15.	Test for internal Clock stability	√		
16.	Test for Noise level measurement	√		
17.	Test for Control Security and Safety for Control outputs	√		
18.	Test for functionality/parameters verification of , CMRs & Heavy duty trip relays	√	√	√
19.	Test for data concentrator	√		
20.	Test for SOE buffer & time data back up	√		
21.	Other functional tests as per technical specification requirements including features in support/ capability (for future)	√		
22.	Test for DCPS of FRTU	√		
23.	Test for compliance of standards for bought items viz. CMRs, MFT, retc	√		
24.	Test for functionality/parameters for bought items viz. CMRs, MFT, retc	√		
25.	Test for test tools	√	√	
B	EMI/EMC IMMUNITY TESTS FOR RTU/FRTU			
26.	Surge Immunity Test as per IEC 60870-2-1	√		
27.	Electrical Fast Transient Burst Test as per IEC-60870-2-1	√		
28.	Damped Oscillatory Wave Test as per IEC 60870-2-1	√		
29.	Electrostatic Discharge test as per IEC 60870-2-1	√		
30.	Radiated Electromagnetic Field Test as per IEC 60870-2-1	√		
31.	Damped Oscillatory magnetic Field Test as per IEC-60870-2-1	√		
32.	Power Frequency magnetic Field Test as per IEC-60870-2-1	√		
C	INSULATION TEST FOR RTU/FRTU			
33.	Power frequency voltage withstand Test as per IEC 60870-2-1	√		
34.	1.2/50 μs Impulse voltage withstand Test as per IEC 60870-2-1	√		
35.	Insulation resistance test	√		
D	ENVIRONMENTAL TEST FOR RTU/FRTU			
36.	Dry heat test as per IEC60068-2-2	√		
37.	Damp heat test as per IEC60068-2-3	√		

Note: 1) Test levels for above type tests mentioned in B, C & D above are elaborated in Table 2 of this Chapter
2) Contractor can provide test certificates for the type tests mentioned in B,C,D & supporting protocols from Govt of India/NABL/International accredited Labs. If not provided, the same needs to be conducted at Govt of India/NABL/International accredited Labs
3) Transducer type test requirements are mentioned in the respective sub section of specification.

Table--2
FRTU Type Test Requirements

Test Nos.	Test Name	EUT Status	Test Level	Power Supply Points		I/O Points	Passing Criteria
				CM	DM	CM	
26	Surge Immunity Test	ON	Level 3	2 kV	1 kV	2 kV	A
27	Electrical Fast Transient Burst Test	ON	Level 3	2 KV	-	1 kV	A
28	Damped Oscillatory Wave Test	ON	Level 3	2.5 kV	1 kV	2.5 kV	A
29	Electrostatic Discharge Test	ON	Level 3	+/- 6 kV in Contact discharge mode or +/- 8 kV in Air discharge mode			A
30	Radiated Electromagnetic Field Test	ON	Level 3	10 /m electric field strength			A
31	Damped Oscillatory Magnetic Field Test	ON	Level 3	30 A/m at 1MHz of magnetic field strength			A
32	Power frequency magnetic field	ON	Level 3	30 A/m of magnetic field strength (Continuous duration sine wave)			A
33.	Power frequency voltage withstand	OFF	-	1 KVrms for 1 minute			No break down or flashover shall occur
34	1.2/50µs impulse voltage withstand	OFF	-	2 kVp			No break down or flashover shall occur
35	Insulation Resistance Test	OFF	-	Measure Insulation resistance using 500 V DC Megger before & after Power Freq & Impulse voltage withstand tests			As per manufacturer standard
36	Dry heat test	ON	-	Continuous operation at 55 ⁰ C for 16 hrs			0
37	Damp heat test	ON	-	at 95% RH and 40 ⁰ C			0

Note:-

1. EUT - Equipment Under Test
2. CM - Common Mode; DM - Differential mode
3. I/O pints do not include Communication ports
4. Passing Criteria
 - 0 - no failure: normal performance within the specified limits
 - A : minor failure : temporary degradation or loss of function or performance which is self-recoverable

7.22 DC POWER SUPPLY SYSTEM

The DC Power Supply system shall be capable of meeting the load requirements for various Telecom equipments, FRTUs and other associated equipment located at indoor, i.e. at the substations,. the AC input to the DCPS system shall be single phase AC which will be provided from the existing system. At these locations the class B & C level of surge protection (between phase-neutral and neutral – protective earth) as specified under IEC 61312, IEC 61024 and VDE 0100-534 shall be installed in the DCPS system. Surge protection devices shall be installed in the DCPS panel to provide adequate protection against current and voltage transients introduced on input AC due to load switching and low energy lightning surges.

7.22.1 General Technical Requirements for SMPS based DC power supply units

SMPS based DC power supply system is to be used in Auto Float-cum-Boost Charge mode as a regulated DC Power source. DCPS system is to be installed indoors and shall be provided with IP21 panels. The System shall consist of the following:

- (a) SMPS modules
- (b) Controller module to control and monitor all DCPS modules.

The number and rating of SMPS modules shall be provided as per the Employer's requirements stipulated in the BOQ. The Panel, Distribution/Switching arrangement shall be provided for the ultimate system capacity. Ultimate System capacity is defined as 150% of the present capacity specified. The ultimate capacity is over and above the requirement of redundancy wherever specified. All factory wiring for the panel shall be for the ultimate capacity so that only plugging-in of SMPS module shall enhance the DC power output. The size of fuses, MCBs, switch, bus etc shall be suitable for the ultimate capacity.

The system shall be sufficiently flexible to serve any load depending on manufacturer's design, rating and number of SMPS modules used in panel and system configuration. To cater for higher load requirements, same type of SMPS modules mounted in the same rack or different racks shall be capable of working in parallel load sharing arrangement. The DCPS system shall be suitable for operation from single phase A.C. mains.

7.22.2 Operational/Component Requirements

The basic modules shall operate at specified ratings and conform to requirements stipulated in this specification. The DCPS system shall meet requirement of the latest TEC specification / IEC/BS for other parameters not specified in this specification. The component parts of the equipment shall be of professional grade of reputed manufacturer to ensure prompt and continuous service and delivery of spare parts. The component shall conform to relevant IEC/IS standards. The contractor shall obtain Employers approval of major component before procurement of the same. Conceptual diagram for DCPS is shown in figure 4-2.

The DCPS shall be suitable for operation at ambient temperature of 0-50 deg and relative humidities up to 95 %.

FIG. 4-2 : CONCEPTUAL CONFIGURATION OF DC POWER SUPPLY (DCPS) SYSTEM

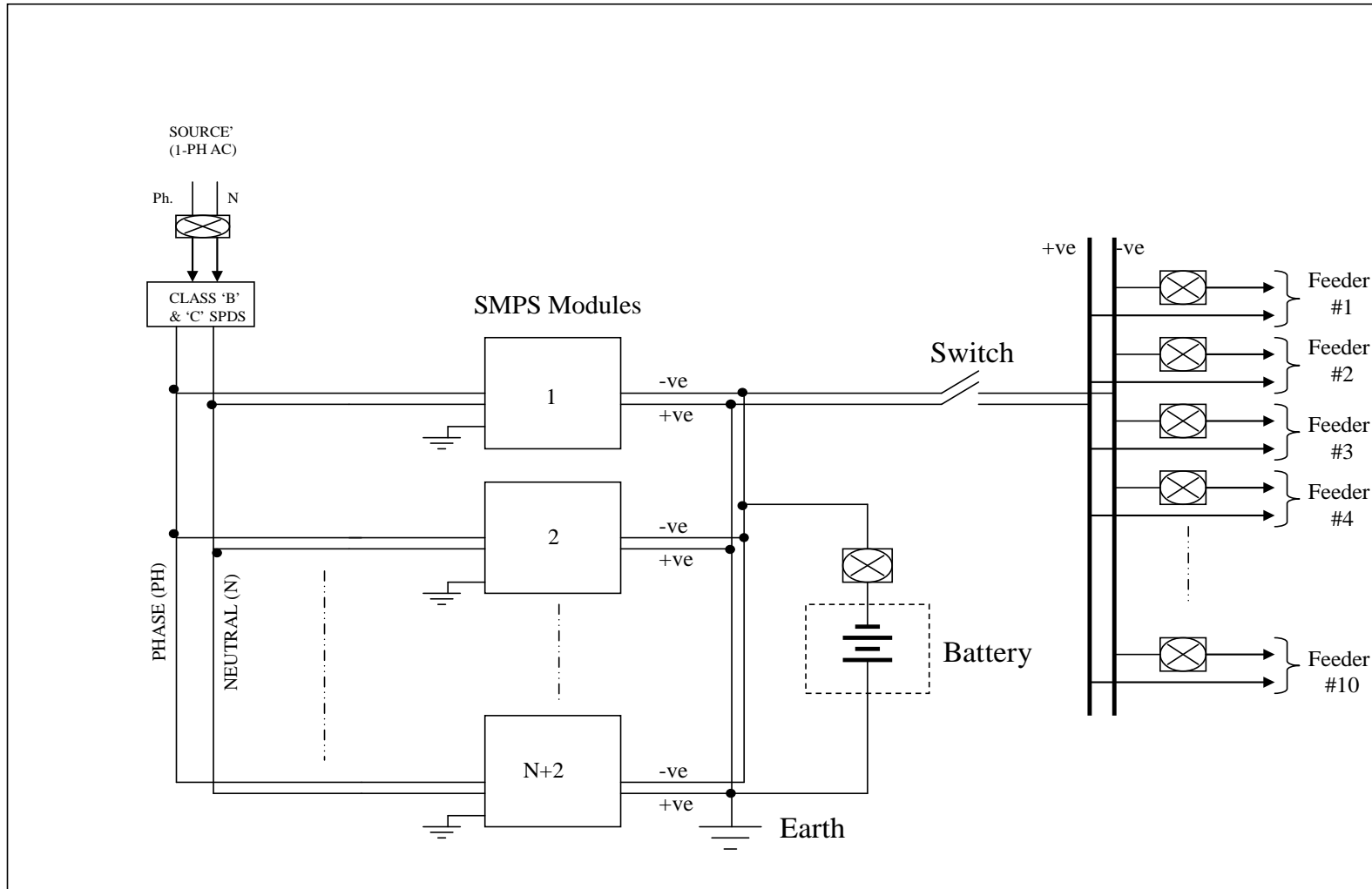

7.23 System and Panel Configuration

The mechanical and electrical requirements of the Panel are described as below:

7.23.1 System Configuration

The SMPS modules shall be accommodated in panels. The system shall employ a modular configuration to provide flexibility, keeping in view the future load requirements of DC Power. The system shall be configured for ultimate capacity. The control, Monitoring, Alarm arrangement and DC & AC distribution shall be provided suitably in the panel.

The number of SMPS modules to be provided in the DCPS system shall be provided in N+2 configuration, where N is the number of SMPS modules to meet the battery charging current (10% of C₁₀ AH Capacity) of the offered battery plus the load requirement stipulated in the BOQ. The current rating of each module shall be considered as output current of the SMPS module at nominal voltage (48V).

It shall be possible to easily mount/remove the modules from the front side of the panel. The SMPS modules/SMPS module sub-racks shall be designed to slide into the panels and fixed securely by a suitable mechanical arrangement.

7.23.2 Constructional Features of Panel

Panel (Enclosure) shall be freestanding type of design. Cable entry shall be from the bottom/top of the enclosures (to be finalized during detailed engineering). The enclosures shall not have doors that are wider than 80 cm and doors shall be hinged with locking as per standard design of the manufacturer. Keyed locking is required with identical keys for all enclosures. The enclosures shall not exceed 120 cm in height. The thickness of the structural frames and load bearing members shall be minimum 2.0 mm and for others shall be minimum 1.5 mm. The panels/boards shall be equipped with necessary cable gland plates. The Contractor shall state the type, size, and weight of all enclosures and indicate the proposed manner of installation.

Wiring within panel shall be neatly arranged and securely fastened to the enclosure by non-conductive fasteners. Wiring between all stationary and moveable components, such as wiring across hinges or to components mounted on extension slides, shall allow for full movement of the component without binding or chafing of the wire. Conductors in multi conductor cables shall be individually colour coded, and numbered at both ends within enclosures.

The enclosures shall be painted inside and outside. The finish colour of all enclosures shall be an aesthetically pleasing and shall be approved by the owner. Further, finish colour of external surfaces shall be preferably of same colour for all enclosures/panels.

Maintenance access to the hardware and wiring shall be through lockable, full height, from doors.

Each panel shall be supplied with 240 VAC, 50Hz single-phase sockets with switch and lighting lamp for panel illumination.

The manufacturer so as to ensure the uninterrupted use of the equipment shall do proper thermal engineering of hardware design. The Panel shall be designed to allow cooling preferably by natural convection. The Bidders shall submit detail design of proposed Panel/enclosure and heat dissipation calculations during detailed engineering. Forced cooling is permitted (DC Fans are permitted in the Panel or SMPS module) for equipment mounted indoors (buildings/rooms/shelters). If cooling is provided at Panel level it shall be provided with additional fan with facility for manual switch over. Proper filtering shall be provided to control dust ingress. There shall be an arrangement for automatic Switching-OFF of fans during AC input failure. The required individual modules may be separated by air baffle to provide effective convection. The manufacturer shall also ensure that the failure of fan does not cause any fire hazards. The failure of any of the fans shall draw immediate attention of the maintenance staff.

7.23.3 Electrical Requirements:

7.23.3.1 AC input supply: The nominal input frequency is 50 Hz, which may vary from 47.5-52.5Hz. The input voltage shall be single phase (Nominal 240V) varying from 190V to 265V.

There shall be an automatic arrangement for shutting off of the SMPS module whenever the input voltage is beyond the specified operating limits with suitable alarm indication. The SMPS module shall resume normal working automatically when the input is restored within the working limits. Hysteresis within specified working limits shall not cause shutting down of the SMPS. A tolerance of $\pm 5V$ may be acceptable for protection & alarm operation.

7.23.3.2 DC output Characteristics of Modules

The module shall be capable of operating in "Auto Float-cum-Boost Charge" mode depending on the condition of the battery sets being sensed by the Control unit.

- (a) The float voltage shall be continuously adjustable & pre-settable at any value in the range of -48 to $-56V$ either at the module or may be set from the common controller configuration. Further, the prescribed float voltage setting shall be based on recommendations of the VRLA battery supplier.
- (b) In Boost charge mode SMPS shall supply battery & equipment current till terminal voltage reaches set value, which is normally $2.3V/cell$ ($55.2V$) or as recommended by the VRLA battery supplier & shall change over to constant voltage mode
- (c) The DC output voltage variation shall not be more than 2% for load variation from 25% load to full load.

7.23.3.3 Current Limiting (Voltage Droop)

The current limiting (Voltage Droop) shall be provided in DCPS modules in float and

boost charge modes of operation. The float/boost charge current limiting shall be continuously adjustable between 50 to 100% of rated output current for output voltage range of –44.4 volts to –56 Volts.

The float and boost charge current limit adjustment shall be provided in the DCPS system. The SMPS modules shall be fully protected against short circuit. It shall be ensured that short circuit does not lead to any fire hazard.

7.23.3.4 Soft/Slow Start Feature:

Soft/Slow start circuitry shall be employed such that SMPS module input current and output voltage shall reach their nominal value within 10 seconds.

The maximum instantaneous current during start up shall not exceed the peak value of the rectifier input current at full load at the lowest input voltage specified.

7.23.3.5 Voltage overshoot/Undershoot:

The requirements of (a) to (c) given below shall be achieved without a battery connected to the output of SMPS module.

- (a) The SMPS modules shall be designed to minimise DC output voltage Overshoot/Undershoot such that when they are switched on the DC output voltage shall be limited to $\pm 5\%$ of the set voltage & return to their steady state within 20 ms for load variation of 25% to 100%.
- (b) The DC output voltage overshoot for a step change in AC mains as specified in clause 4.3.12 Electrical Requirements shall not cause shut down of SMPS module and the voltage overshoot shall be limited to $\pm 5\%$ of its set voltage and return to steady state within 20ms.
- (c) The modules shall be designed such that a step load change of 25 to 100% and vice versa shall not result in DC output voltage Overshoot/Undershoot of not more than 5% and return to steady state value within 10 ms without resulting the unit to trip.

7.23.3.6 Electrical Noise:

The Rectifier (SMPS) Modules shall be provided with suitable filter at output with discharge arrangements on shut down of the modules. The Psophometric Noise and ripple shall be as per relevant standards.

7.23.3.7 Parallel Operation:

SMPS modules shall be suitable for operating in parallel with one or more modules of similar type, make and rating, other output conditions remaining within specified limits.

The current sharing shall be within $\pm 10\%$ of the average current per rectifier module individual capacity of each rectifier module in the system (mounted in the same or

different Panels) when loaded between 50 to 100% of its rated capacity for all other working conditions.

7.24 Protection

The SMPS module, which has failed (for any reason) shall be automatically isolated from the rest of the modules and an alarm shall be initiated for the failure.

7.24.1 DC Over voltage protection

DCPS shall be fitted with an internal over voltage protection circuit.

In case output DC voltage exceeds $-57V$ or as per the recommendations of the manufacturer of batteries, the over voltage protection circuit shall operate & shut off the faulty module. A tolerance of $\pm 0.25V$ is permitted in this case.

Shutting off of faulty SMPS module shall not affect the operation of other SMPS modules operating in the Panel. Operation of over voltage shut down shall be suitably indicated and extended monitoring/control unit. The circuit design shall ensure protection against the discharge of the Battery through the SMPS module in any case. The over voltage protection circuit failure shall not cause any safety hazard.

7.24.2 Fuse/Circuit Breakers

Fuses or miniature circuit breakers (MCB) shall be provided for each SMPS module as follows:

1. Live AC input line
2. Control Circuit

All fuses/circuit breaker used shall be suitably fault rated.

7.24.3 AC Under/Over Voltage Protection

AC input Under/Over voltage protection shall be provided as per clause 4.3.12 for Electrical Requirements.

7.24.4 Over Load/Short Circuit Protection

The SMPS shall be protected for Over load/Short circuit as per clause 4.3.14 Current Limiting (Voltage Droop).

7.24.5 Alarms and indicating lamps

Visual indications/display such as LEDs, LCDs or a combination of both shall be provided on each SMPS module for detection of SMPS module failure.

7.25 Termination

Suitable termination arrangements shall be provided in the panel for termination of inter cubicle cables from other equipment such as owners ACDB, Telecom and other

associated equipments and alarm cables. All the termination points shall be easily accessible from front and top. AC and DC terminals shall be separated by physical barriers to ensure safety. All the terminals except AC earth shall be electrically isolated.

7.25.1 Terminations

All terminations including through MCBs shall be through lock and screw type terminations. Load and batteries shall be connected to DCPS through appropriate MCBs. The isolation of any of the battery from the load shall create an alarm. DC distribution shall be provided with adequate no of feeders (with three no of spare) with appropriate MCBs (6 Amp thru 32 Amp) for termination of the loads. Actual rating of the MCBs and no of feeders shall be finalized during the detail engineering.

DC distribution may be done either on wall mounted panel or on the DCPS panel. The proper rated MCB shall be provided at the combined output of the SMPS modules (if not provided at each SMPS module). All the AC, DC and Control/alarm cabling shall be supplied with the Panel. All DC +ve and -ve leads shall be clearly marked. All conductors shall be properly rated to prevent excessive heating.

7.26 Power Cables

All power cables shall be stranded copper conductor XLPE/PVC insulated and PVC sheathed, single core/two core/three core/four core, 1100V grade as per IS 1554 Part-I.

7.26.1 Earthing Cables

Earthing cables between equipment and grounding bus bars shall be minimum size 70 mm² stranded conductors copper/copper strip, rated at 300 volts. All hinged doors shall be earthed through flexible earthing braid. Signal and Safety earthing shall be provided separately.

7.27 Alarms

Following Visual indications/display such as LEDs, LCDs or a combination of both shall be provided to indicate :

Functional Indications for local monitoring:

- a) Mains available (not mandatory if provided at module level)
- b) DCPS/SMPSs in Float
- c) DCPS/SMPSs in Charge Mode

Alarm Indication for local monitoring:

- a) Load Voltage High /Low
- b) DCPS module/SMPS fail
- c) Mains out of range
- d) System Over Load
- e) Mains "ON"/Battery Discharge

- f) Temp. Compensation fail
- g) Battery fail/isolated

All the protections/alarms shall be within tolerance of 0.25V in case of DC voltage, 1% in case of DC current and $\pm 5V$ for AC voltage

Alarm Indication for remote monitoring:

- a) Input AC mains supply fail alarm
- b) Battery low voltage (Pre cut off) alarm
- c) DCPS module fail

Potential free Contacts in two numbers for each of the above remote monitoring alarms (one for remote alarm interfaced through RTU and one redundant for local monitoring at suitable location) shall be provided. All these potential free contacts are to be wired and terminated at the suitable location for termination to RTU.

7.28 Temperature Compensation for Battery

There shall be provision for monitoring the temperature of battery and consequent arrangement for Automatic temperature compensation of the SMPS output voltage to match the battery temperature dependant charge characteristics. The output voltage of the rectifier in Float/Charge operation shall decrease or increase at the rate of 72 mV (24 cell battery) per degree increase or decrease in temperature over the set voltage or as may be recommended by the VRLA Battery supplier. The output voltage shall decrease till the open circuit voltage of the battery is reached. The open circuit voltage range shall be settable between 2.1V/cell to 2.2V/cell. The increase in output voltage due to decrease in temperature has been taken care of by the tripping of the unit due to output voltage high (57V) protection. Failure of temperature compensation circuit including sensors shall create an alarm and shall not lead to abnormal change in output voltage.

7.29 Digital Meters/Display Unit

There shall be provision to monitor the following parameters through digital meters or digital display units:

- (a) Input AC voltage.
- (b) Out put DC voltage
- (c) Output DC current of charger
- (d) Battery current
- (e) Load current.

The Digital display of meters or display unit shall be with minimum $3\frac{1}{2}$ digital display of height 12mm and shall have an accuracy 1.5% or better.

7.30 Type Testing of DCPS

The contractor shall supply DCPS System, which was already type tested. The test

reports for immunity, Emission and surge must be in accordance with relevant IEC/CISPR standards shall be submitted . The Contractor shall submit the DCPS type test reports of earlier conducted tests on the same make, model, type & rating which shall include the following tests. For type testing requirements in addition to provisions of chapter 8 is also to be complied.

Type Tests on DCPS

- 1 Surge immunity (Level 4- as per IEC 61000-4-5)
- 2 Electrical Fast Transients/Burst (Level 4 – as per IEC 61000-4-4)
- 3 Electrostatic Discharge (Level 4 – as per IEC 61000-4-2)
- 4 Radiated Electromagnetic Field (Level 3 – as per IEC 61000-4-3)
- 5 Conducted disturbances induced by radio-frequency field (Level 3 – as per IEC 61000-4-6)
- 6 Damped oscillatory magnetic field (Level 3 – as per IEC 61000-4-10)
- 7 Voltage dips, short interruptions and voltage variations (Level 2 – as per IEC 61000-4-11)
- 8 Conducted Emission (Level - Class A, Group 1 as per IEC CISPR 11)
- 9 Radiated Emission (Level - Class A, Group 1 as per IEC CISPR 11)
- 10 Verification of Protection class (IP 21) for enclosure
- 11 Safety Tests (as per IEC 60950)
- 12 Burn in test for 72 hours at maximum operating temperature

7.31 Factory/Site Testing of DCPS

The factory/site tests to be carried out on DCPS system/module in the factory and site are listed respectively in Table below. The manufacturer shall conduct routine tests on all the systems/modules and submit the report before offering for FAT . The routine tests shall include atleast the tests mentioned under FAT.

Sl.No.	Test	FAT	SAT
Tests on DCPS System			
1.	Mechanical & Visual Check Tests	√	√
2.	Insulation Test.	√	
3.	High Voltage Withstand Test	√	
4.	Switch On Test	√	√
5.	DCPS Low voltage & High voltage limits check Test	√*	√
6.	Pre-alarm test for Battery Voltage Low	√*	√
7.	Battery Low Voltage Disconnect Level Test	√*	√
8.	AC Input Low and High voltage limits check Test	√*	
9.	Rectifier Fail Alarm Test	√*	√
10.	Voltage Regulation Test	√*	√
11.	Current Sharing Test	√*	
12.	Total Output Power Test	√*	√
13.	Hot Plug In Test	√*	√

Sl.No.	Test	FAT	SAT
14.	Calibration & Parameter settings	√*	√
15.	Automatic Float cum Boost Charge Mode Change Over Test	√*	√
16.	Battery Path Current Limiting Test	√*	√
17.	Battery Charging and full load Current Test	√*	√
18.	Battery Temperature Compensation Test	√*	
19.	Total Harmonic distortion Test	√*	
20.	Burn in Test for 8 hours at max operating temperature	√*	
Tests on SMPS module			
21	Mechanical & Visual Check Test	√*	
22	Module-On Test	√*	
23	Input low/high voltage cut-off test	√*	
24	Voltage Droop Test	√*	
25	Voltage Regulation Test	√*	
26	Power Output & Current Limit Test	√*	
27	DC High Voltage Test	√*	
28	O/P Voltage Ripple Test	√*	
29	Psophometric Noise Test	√*	
30	Efficiency Test	√*	
31	Power Factor	√*	
32.	Input Current Limit	√*	
33.	Input AC Frequency Range Test	√*	
34.	Rectifier Dynamic Response	√*	
35.	Output Short Circuit Test	√*	
36.	Hold up Time Test	√*	

Note* : These tests (Sl. No. 5-36) shall be conducted on 10% samples of the offered batch and other tests (Sl. No 1-4) shall be conducted on each equipment during the FAT.

7.32 DISTRIBUTION BOARDS

AC distribution boards shall be provided for UPS input and output power distribution. The distribution boards shall distribute power and provide protection against failures on feeder circuits, to the equipment. The Contractor shall be responsible for design, engineering, manufacturing, supply, storage, installation, cabling, testing & commissioning of AC distribution boards required for distribution of power. The nominal input frequency is 50 Hz, which may vary from 47.5-52.5Hz. The phase to neutral input voltage shall be (Nominal 240V) varying from 190V to 265 V.

The Input ACDB will cater for the load requirements of DC power supply system, air-conditioning alarm system, fire protection alarm system, lighting loads and one spare of 20A minimum, in addition to UPS system load. The Output ACDB shall cater for only critical loads in the control centre. The number of feeders and their ratings in the output ACDB shall be decided during detail engineering. At least five spare feeders in the

output panel shall be provided.

All MCCBs shall conform to IEC-60947-2 & IS 13947-2/IEC 947-2, IEC-60898 and IS 8828 and shall be of Four (4) Pole type of requisite rating. MCBs used for load feeders in output ACDB shall be of minimum curve B characteristics. The load feeders shall be coordinated with requirement of loads of computers and other loads.

7.32.1 Enclosures/Panels

The equipments of ACDBs shall be physically mounted in freestanding enclosures/panels. MCCBs and sub-assemblies shall be easily replaceable and maintainable. Cable entry shall be from the bottom/top of the enclosures (to be finalized during detailed engineering). The Contractor shall state the type, size and weight of all enclosures and indicate the proposed manner of installation. The applicable degree of protection of enclosures shall be at least IP21. The thickness of the structural frames and load bearing members shall be minimum 2.0 mm and for front & rear, sides and top covers shall be minimum 1.6 mm. For wall mounted type of output ACDB the above requirements shall not be applicable.

7.32.2 Equipment/Panel Earthing & Surge Protection

Each enclosure shall include suitable safety earth networks as per clause 4.2.3.5. . Surge protection devices shall be installed in the input ACDB to provide adequate protection against current and voltage transients introduced on input AC due to load switching surges. These protection devices shall be in compliance with IEC- 61312, IEC- 61024 and VDE 0100-534 for following surges:

a) Low Voltage Surges (Class C)

Between	Requirement
R, Y, B & N	$I_n \geq 10 \text{ kA}, 8/20 \mu\text{S}$ for each phase
N & PE	$I_n \geq 20 \text{ kA}, 8/20 \mu\text{S}$

I_n = Value of Nominal Discharge Current.

7.33 CABLING REQUIREMENTS

The contractor shall supply, install and commission all power cables, control cables, network interface cables and associated hardware (lugs, glands, cable termination boxes etc.) as required for all equipment. The contractor shall be responsible for cable laying and termination at both ends of the cable. The Contractor shall also be responsible for termination of owner supplied cables if any at contractor's equipment end including supply of suitable lugs, glands, terminal blocks & if necessary cable termination boxes etc. All cabling, wiring and interconnections shall be installed in accordance with the following requirements.

7.33.1 Power Cables

All external power cables shall be stranded aluminium/Copper conductor, armoured XLPE/PVC insulated and sheathed; 1100V grade as per IS 1554 Part-I. The conductor for the Neutral connection from UPS to Output ACDB shall be sized 1.8 times the size of the Phase conductors to take care of the non-linear loads. However, the cable between UPS & Battery bank shall be of copper conductor (armoured type).

7.33.2 Cable Identification

Each cable shall be identified at both ends, which indicates the cable number, and the near-end and far-end destination. All power cables shall have appropriate colour for identification of each phase/neutral/ground. Cable marking and labelling shall comply with the requirements of the applicable standards.

7.33.3 Cable and Hardware Installation

The Contractor shall be responsible for supplying, installing, and terminating all cables and associated hardware (lugs, glands, etc.), required to mechanically and electrically complete the installation of facilities for the project.

7.33.4 Enclosures/Panels design

Enclosures/panel shall be of freestanding type of design. Cable entry shall be from the bottom/top of the enclosures (to be finalized during detailed engineering). The enclosures shall not have doors that are wider than 80 cm and doors shall be hinged with locking as per standard design of the manufacturer. Keyed locking is required with identical keys for all enclosures. The enclosures shall not exceed 120 cm in height. The thickness of the structural frames and load bearing members shall be minimum 2.0 mm and for others shall be minimum 1.5 mm. The panels/boards shall be equipped with necessary cable gland plates. The Contractor shall state the type, size and weight of all enclosures and indicate the proposed manner of installation.

Wiring within panel shall be neatly arranged and securely fastened to the enclosure by non-conductive fasteners. Wiring between all stationary and moveable components, such as wiring across hinges or to components mounted on extension slides, shall allow for full movement of the component without binding or chafing of the wire. Conductors in multi-conductor cables shall be individually colour coded, and numbered at both ends within enclosures.

The enclosures shall be painted inside and outside. The finish colour of all enclosures shall be aesthetically pleasing and shall be approved by the owner. Further, finish colour of external surfaces shall be preferably of same colour for all enclosures/panels.

Maintenance access to the hardware and wiring shall be through full height lockable doors.

Each panel shall be supplied with 240 VAC, 50Hz single-phase sockets with switch.

Each ACDB and equipment within ACDB enclosures shall be clearly labelled to identify the enclosure/equipment. All labelling shall be consistent with Contractor-supplied

drawings.

7.33.5 Enclosure/Panel Earthing

Each enclosure shall include suitable earth networks within the enclosure. Earth network shall be a copper bus bar, braid or cable inside enclosures.

The safety earth network shall terminate at two/more studs for connecting with the earthing grid. Safety earthing cables between equipment and enclosure grounding bus bars shall be of minimum size of 6 mm², stranded copper conductors, rated at 300 volts. All hinged doors shall be earthed through flexible earthing braid.

For all enclosures requiring AC input power, the green earthing wire from the AC input shall be wired to the safety-earthing stud. The Contractor shall provide all required cabling between enclosures for earthing. The contractor shall connect safety and signal earths (as applicable) of each enclosure to the nearest earth grid/earth riser through suitable 50X6 sq. mm. GI/25x3 Cu strips. The contractor may use the existing grid wherever available. In case the suitable earthing grid is not available the same shall be made by the contractor.

The signal earthing network shall terminate at a separate stud connection, isolated from safety ground. The stud connection shall be sized for an external earthing cable equipped with a suitable lug.

All earthing connections to equipment shall be made directly to each equipment chassis via earthing lug and star washer. Use of the enclosure frame, skins, or chassis mounting hardware for the earthing network is not acceptable.

7.34 BATTERY REQUIREMENTS

The contractor shall supply Valve Regulated Lead Acid (VRLA) maintenance free Battery DCPS system. Each battery set shall have sufficient capacity to maintain output at full rated load for duration as defined in **BOQ** The Bidder shall furnish detailed battery sizing calculations along with all arrangements and supporting structures, for DCPS system being proposed, along with the bid. In all cases the battery is normally not allowed to discharge beyond 80% of rated capacity (80% DOD) at 10 hours rate of discharge.

The contractor supplying the cells/batteries as per this document shall be responsible to replace/repair free of charge, the battery/cell becoming faulty, owing to defective workmanship or material as per the provisions of the bid document.

Battery sizing calculation for UPS shall be done considering the actual charging achieved in eight hours i.e. in case 100% charging is not achieved in eight hours the Ah of the battery shall be enhanced by the ratio of charging actually achieved in eight hours.

7.34.1 Constructional Requirements

The design of battery shall be as per field proven practices. Partial plating of cells is not permitted. Paralleling of cells externally for enhancement of capacity is not permitted. Protective transparent front covers with each module shall be provided to prevent accidental contact with live module/electrical connections. It shall be possible to easily replace any cell of the battery at site in normal working condition.

7.34.2 Containers

The container material shall have chemical and electro-chemical compatibility and shall be acid resistant. The material shall meet all the requirements of VRLA batteries and be consistent with the life of battery. The container shall be fire retardant and shall have an Oxygen Index of at least 28%. The porosity of the container shall be such that so as not to allow any gases to escape except from the regulation valve. The tensile strength of the material of the container shall be such that so as to handle the internal cell pressure of the cells in the worst working condition. Cell shall not show any deformity or bulge on the sides under all working conditions. The container shall be capable of withstanding the rigours of transport, storage and handling. The containers shall be enclosed in a steel tray.

7.34.3 Cell Covers

The cell covers shall be made of suitable material compatible with the container material and permanently fixed with the container. It shall be capable to withstand internal pressure without bulging or cracking. It shall also be fire retardant. Fixing of Pressure Regulation Valve & terminal posts in the cover shall be such that the seepage of electrolyte, gas escapes and entry of electro-static spark are prevented.

7.34.4 Separators

The separators used in manufacturing of battery cells, shall be of glass mat or synthetic material having high acid absorption capability, resistant to sulphuric acid and good insulating properties. The design of separators shall ensure that there is no misalignment during normal operation and handling.

7.34.5 Pressure Regulation Valve

Each cell shall be provided with a pressure regulation valve. The valve shall be self re-seal able and flame retardant. The valve unit shall be such that it cannot be opened without a proper tool. The valve shall be capable to withstand the internal cell pressure specified by the manufacturer.

7.34.6 Terminal Posts

Both the +ve and –ve terminals of the cells shall be capable of proper termination and shall ensure its consistency with the life of the battery. The surface of the terminal post extending above the cell cover including bolt hole shall be coated with an acid resistant and corrosion retarding material. Terminal posts or any other metal part which is in

contact with the electrolyte shall be made of the same alloy as that of the plates or of a proven material that does not have any harmful effect on cell performance. Both +ve and -ve posts shall be clearly and unambiguously identifiable.

7.34.7 Connectors, Nuts & Bolts, Heat Shrinkable Sleeves

Where it is not possible to bolt the cell terminals directly to assemble a battery, separate non-corroding lead or copper connectors of suitable size shall be provided to enable connection of the cells. Copper connections shall be suitably lead coated to withstand corrosion due to sulphuric acid at a very high rate of charge or discharge.

Nuts and bolts for connecting the cells shall be made of copper, brass or stainless steel. Copper or brass nuts and bolts shall be effectively lead coated to prevent corrosion. Stainless steel bolts and nuts can be used without lead coating.

All inter cell connectors shall be protected with heat shrinkable silicon sleeves for reducing the environmental impact including a corrosive environment.

7.34.8 Flame Arrestors

Each cell shall be equipped with a Flame Arrestor to defuse the Hydrogen gas escaped during charge and discharge. Material of the flame arrestor shall not affect the performance of the cell.

7.34.9 Battery Bank Stand

All batteries shall be mounted in a suitable metallic stand/frame. The frame shall be properly painted with the acid resistant paint. The suitable insulation shall be provided between stand/frame and floor to avoid the grounding of the frame/stand.

7.34.10 Capacity Requirements

When the battery is discharged at 10-hour rate, it shall deliver 80% of C (rated capacity, corrected at 27°Celsius) before any of the cells in the battery bank reaches 1.85V/cell.

All the cells in a battery shall be designed for continuous float operation at the specified float voltage throughout the life. Float voltage of each cell in the string shall be within the average float voltage/cell $\pm 0.05V$ band.

The capacity (corrected at 27°Celsius) shall also not be less than C and not more than 120% of C before any cell in the battery bank reaches 1.75V/cell. The battery voltage shall not be less than the following values, when a fully charged battery is put to discharge at C/10 rate:

- (a) After Six minutes of discharge : 1.98V/cell
- (b) After Six hours of discharge : 1.92V/cell
- (c) After 8 hours of discharge : 1.85V/cell
- (d) After 10 hours of discharge : 1.75V/cell

Loss in capacity during storage at an average ambient temperature of 35° Celsius for a period of 6 months shall not be more than 60% and the cell/battery shall achieve 85% of its rated capacity within 3 charge/discharge cycles and full rated capacity within 5 cycles, after the storage period of 6 months. Voltage of each cell in the battery set shall be within 0.05V of the average voltage throughout the storage period. Ampere-hour efficiency shall be better than 90% and watt-hour efficiency shall be better than 80%.

7.34.11 Expected Battery Life

The battery shall be capable of giving more than 1200 charge/discharge cycles at 80% Depth of discharge (DOD) at an average temperature of 27° Celsius. DOD (Depth of Discharge) is defined as the ratio of the quantity of electricity (in Ampere-hour) removed from a cell or battery on discharge to its rated capacity. The battery sets shall have a minimum expected operational life of 5 years at normal operating conditions or 1200 charge / discharge cycles (whichever is early).

7.34.12 Routine Maintenance of Battery system

For routine maintenance of battery system, the contractor shall supply 1 set of following tools:

- a. Torque wrench.
- b. Tool for opening /closing of pressure regulation valve of battery.
- c. Hand held digital Multimeter for measurement of resistance, AC/DC voltages.

7.34.13 Testing of Battery

The contractor shall supply type tested battery as required for DCPS. The Contractor shall submit the Battery type test reports of earlier conducted tests on the same make, model, type & rating as offered as per the IEC 60896 or equivalent IS/EN/BS standards . These Type test reports shall be submitted for the highest rating battery to be supplied under the contract. For type testing requirements in addition to provisions of this chapter 8 is also to be complied. The tests mentioned in the Table 4.2 shall be conducted on the battery at site and factory.

TABLE 4.2 LIST OF FACTORY & SITE TESTS FOR BATTERY

S. No.	Test	Factory Tests	Site Tests
1.	Physical Verification	√	√
2.	C/10 Capacity test on the cell	√	
3.	8 Hrs. Charge and 30 minutes (duration as specified) discharge test at full rated load		√

7.35 Testing Requirements

The requirements for type tests, factory acceptance tests and field acceptance testing have been specified under the respective clauses. After completion of field acceptance testing the auxiliary power supply system shall be put under availability test for fifteen (15) days. Availability test shall be carried out by the employer/owner. During the availability test the APS shall be used as required to be used for rest of the life. In case of any failure or mal-operation during this period the contractor shall take all necessary action to rectify the problems. The APS shall be accepted only after rectification of the problems by the contractor in a manner acceptable to the employer.

7.36 Documentation

The following specific document for items covered under this section shall be submitted which shall be in addition to the applicable general document required under Chapter 8 .

- Data Requirement Sheets (DRS)
- Battery sizing calculations
- Cable sizing calculations
- Inventory of the hardware
- Panel General arrangement drawing
- Panel Internal General Arrangement drawing indicating modules, major devices/components location etc.
- Installation drawings
- Schematic drawings
- Type Test reports
- FAT plan & procedure
- SAT plan & procedure
- External cable laying & termination schedule details
- Availability test plan & procedure

7.37 Mandatory Spares

List of mandatory spares for UPS, DCPS are mentioned in the BOQ

Chapter 8

TESTING , DOCUMENTATION & QA

8.0 General

This section describes the specific requirements for testing and documentation of the RT-DAS system .The test requirements given in relevant chapters shall also be followed

8.1 Type testing –

Equipment wherever mentioned in the specification for type testing shall conform to the type tests listed in the relevant chapters. Type test reports of tests conducted in NABL accredited Labs or internationally accredited labs with in last 5 years from the date of bid opening may be submitted. In case, the submitted reports are not as per specification, the type tests shall be conducted without any cost implication to employer.

8.2 Factory Acceptance Tests (FAT) (One time test for data centre hw & sw functions, performance and availability)

The RT-DAS system shall be tested at the Contractor's facility for entire state for functional and performance compliance . All hardware and software associated with the RT-DAS system and at least FRTUs of one town (Max 20 FRTUs) shall be staged for the factory testing and all remaining FRTUs shall be simulated for the complete point counts (ultimate size). The requirements for exchanging data with other computer systems like , IT system under R-APDRP shall also be simulated.

Each of the factory tests described below (i.e. the hardware integration test, the functional performance test, integrated system test and unstructured tests) shall be carried out under factory test for the RT-DAS system. The factory tests, requiring site environment, shall be carried out during the Field Tests after mutual agreement for the same from owner.

Factory Test / Routine of FRTU and DCPS shall be made on 1 % random sample of each lot or minimum 1 whichever is lower as per tables for test given for respective equipment

8.2.1 Hardware Integration Test

The hardware integration test shall be performed to ensure that the offered computer hardware, conforms to this Specification requirements and the Contractor-supplied hardware documentation. All the RT-DAS system hardware shall be integrated and staged for testing. Applicable hardware diagnostics shall be used to verify the hardware configuration of each equipment. The complete hardware & software bill of quantity including software licenses & deliverables on electronic media shall also be verified.

8.2.2 System Build test

After completion of hardware integration test, the RT-DAS system shall be built from the backup software on electronic media (CDs/Magnetic Tapes etc) to check the completeness of backup media for restoration of system in case of it's crashing/failure. The software deliverables shall include one copy of backup software on electronic media.

8.2.3 Functional Performance Test

The functional performance test shall verify all features of the RT-DAS hardware and software. As a minimum, the following tests shall be included in the functional performance test:

- (a) Testing of the proper functioning of all RT-DAS & other software application softwares in line with the requirements of various sections of technical specification.
- (b) Simulation of field inputs (FRTU) from test panels that allow sample inputs to be varied over the entire input range
- (c) Simulation of field input error and failure conditions
- (e) Verification of FRTU communication Protocol IEC60870-5-104 /101 etc
- (f) Verification of MFT communication Protocol MODBUS etc
- (g) Verification of compliance of supporting interfaces such as IEC61850, IEC60870-5-103 etc.
- (h) Verification of Security & Encryption using SSL for FRTU connectivity.
- (i) Verification of Data Integration from RT-DAS system other systems viz IT Systems etc XML based data for feeder wise GIS information (as available) or created feeder wise consumer count and update mechanism from IT system
- (j) Exchange of SAIFI/SAIDI report to IT using ODBC connectivity or suitable method
- (k) Verification of interoperability profile of all profiles of all protocols being used.
- (i) Testing of all user interface functions, including random tests to verify correct database linkages
- (j) Simulation of hardware failures and input power failures to verify the reaction of the system to processor and device failure

- (k) Demonstration of all features of the database, display, and report generation and all other software maintenance features on both the primary and backup servers. Online database editing shall also be tested on primary server.
- (l) Demonstration of the software utilities, and development tools.
- (m) Verification that the RT-DAS computer system meets or exceeds employer's performance requirements (as per table for peak & normal loading in chapter 10 Verification of Design parameters as mentioned in Chapter 10 & wherever defined in the specification.
- (n) Verification that ultimate expansion requirements are met.
- (o) Unstructured testing of the RT-DAS system by employer. The unstructured tests shall include the test, which are not in the approved test procedures and may be required to verify the compliance to the specification . (Max 20% of total testing

8.2.4 Continuous operation Test (48 hours)

This test shall verify the stability of the RT-DAS hardware and software after the functional performance test has been successfully completed. During the test, all RT-DAS functions shall run concurrently and all Contractor supplied equipment shall operate for a continuous 48 (forty eight) hour period with simulated exchange with other interconnected system viz. R-APDRP IT system etc. The test procedure shall include periodic repetitions of the normal and peak loading scenarios defined. These activities to be tested may include, but shall not be limited to, database, display, and report modifications, configuration changes (including user-commanded processor and device failover), switching off of a primary server and the execution of any function described in this Specification. During the tests, uncommanded functional restarts or server/device failovers are not allowed; in case the problems are observed , the Contractor shall rectify the problem and repeat the test.

8.3 Field Tests (Site Acceptance tests -SAT)

The RT-DAS system shall be tested at the site. All hardware and software associated with the RT-DAS system along with FRTUs along with all field devices including MFTs connected shall be tested under the field tests.

8.3.1 Field Installation Tests(FRTU wise)

The equipment which has undergone the factory testing shall be installed at site and integrated with the FRTU and other computer systems though the communication medium. This is a progressive test i.e. shall be done when particular FRTU is installed.

The field installation test shall include the following:

- (a) Proper installation of all delivered hardware as per approved layout.
- (b) Interconnection of all hardware
- (c) Interconnection with communication equipments

- (d) Interconnection with power supply
- (e) Diagnostic tests to verify the operation of all hardware
- (f) Random checking of RT-DAS software basic functions

The Contractor shall be responsible for performing the field installation tests and Employer may witness these tests

8.3.2 End-to-End Test (FRTU wise)

.This is a progressive test i.e. shall be done when particular local installation of FRTU is done (Field installation test)..

After the field installation tests, the Contractor shall carry out end-to-end test to verify following of the installed FRTU:

- (a) the communication of FRTUS with RT-DAS system
- (b) the FRTU communication channel monitoring in the RT-DAS system
- (c) the mapping of RT-DAS database with FRTU database for FRTU
- (d) the mapping of RT-DAS database with displays and reports

The Contractor shall provide the details of all the variances observed and corrections carried out during end to end test.

8.3.3 Field Performance Test (Town wise)

After the end to end test of all FRTUs in the towns considered for completion and achievement of the objective, the Contractor shall conduct the field performance test to verify the functional performance of the system in line with the technical specification which includes the following:

- (a) the communication of other system i.e R-APDRP IT system
- (b) Mapping of RT-DAS database with other system database
- (c) Verify that all the variances observed during the Factory test are fixed and implemented.
- (d) Conduction of the Factory tests deferred (tests requiring site environment)
- (e) Functional tests of RT-DAS system
- (f) Verify the execution rates of all RT-DAS application
- (g) Verify update rate & time for data update & control command execution as per specification requirements
- (h) Verify the response time of all RT-DAS applications.
- (i) Verify the response time for User interface requirements
- (j) Testing of all features of the database, display, and report generation and all other software maintenance features on both the primary and backup servers. Online database editing shall also be tested on primary server.
- (k) Conduction of unstructured tests as decided by the Employer
- (a)
- (b)

8.4 System Availability Test (120 hours) utility wise

Contractor shall provide & approve theoretical and practical figures used for this calculation at the time of detailed engineering. The calculation shall entail reliability of each individual unit of the System in terms of Mean Time Between Failures (MTBF and a Mean time to Repair (MTTR) as stated by OEM. Reliability figures of existing equipment shall be supported by evidence from operational experience at similar types of installation / figure given by OEM.

System availability tests shall be conducted after completion of the field tests. The system availability test shall apply to the RT-DAS system (hardware and software) integrated with its FRTU and R-APDRP IT SYSTEM. However, the non-availability of FRTU/R-APDRP –IT system etc & Communication System shall not be considered for calculating system availability. However, FRTU, Auxiliary power supply shall be tested as per the provisions given in their chapters.

The RT-DAS system (hardware and software systems) shall be available for 99.5% of the time during the 120 hours (5 days) test period. However, there shall not be any outage /down time during last 48 Hours of the test duration. In case the system availability falls short of 99.5%, the contractor shall be allowed to repeat the system availability test after fixing the problem, failing which the system shall be upgraded by the contractor to meet the availability criteria without any additional cost implication to the owner.

Availability tests of FRTUs shall be conducted along with System availability test for 120 hours. Each FRTUs shall exhibit minimum availability of 98%. In case the FRTU availability falls short of 98%, the contractor shall be allowed to repeat the FRTU availability test (for failed FRTU only) after fixing the problem, failing which the equipment shall be upgraded by the contractor to meet the availability criteria without any additional cost implication to the owner.

In the event of unsuccessful reruns of the availability test, employer may invoke the default provisions described in the General Conditions of Contract.

The RT-DAS system shall be considered as available if

- a) one of the redundant hardware is available so that all the RT-DAS applications are functional to ensure the design & performance requirement as envisaged in the specification
- b) atleast one of the operator console is available
- c) All RT-DAS applications are available
- d) Data exchange with other system is available
- e) SAIFI/SAIDI is report getting generated as envisaged

However each device, including servers, shall individually exhibit a minimum availability of 98%.

The non-availability of following Non-Critical functions shall not be considered for calculations of system availability; however these functions should be available for 98% of the time.

- (a) Database modification and generation
- (b) Display modification and generation
- (c) Report modification and creation

During the availability test period, employer reserves the right to modify the databases, displays, reports, and application software. Such modifications will be described to the Contractor at least 24 hours in advance of implementation to allow their impact on the availability test to be assessed, except where such changes are necessary to maintain control of the power system.

Once system availability test is done. Certification for cyber security from NCIIPC/ CERT.IN is to be obtained by Contractor . Till the time system will be considered as “ Go Live ” only

Thereafter site shall be considered as “**operational acceptance**” of the system.

8.4.1 Downtime

Downtime occurs whenever the criteria for successful operation are not satisfied. During the test period, owner shall inform the Contractor for any failure observed. For attending the problem the contractor shall be given a reasonable travel time of 8 hours. This service response time shall be treated as hold time and the test duration shall be extended by such hold time. The downtime shall be measured from the instant, the contractor starts the investigation into the system and shall continue till the problem is fixed. In the event of multiple failures, the total elapsed time for repair of all problems (regardless of the number of maintenance personnel available) shall be counted as downtime. Contractor shall be allowed to use mandatory spares (on replenishment basis) during commissioning & availability test period. However it is the contractor’s responsibility to maintain any additional spares as may be required to maintain the required system availability individual device/ equipment availability. All outage time will first be counted but if it is proven to be caused by hardware or software not of Contractor’s scope, it will then be deducted.

8.4.2 Holdtime

During the availability test, certain contingencies may occur that are beyond the control of either employer or the Contractor. These contingencies may prevent successful operation of the system, but are not necessarily valid for the purpose of measuring RT-DAS availability. Such periods of unsuccessful operation may be declared "holdtime" by mutual agreement of employer and the Contractor. Specific instances of holdtime contingencies could be Scheduled shutdown of an equipment, Power failure to the equipment, Communication link failure.

8.5 Documentation

The complete documentation of the systems shall be provided by the contractor. Each revision of a document shall highlight all changes made since the previous revision. Employer's intent is to ensure that the Contractor supplied documentation thoroughly and accurately describes the system hardware and software.

The contractor shall submit the paper copy of all necessary standard and customised documents for RT-DAS in 2 sets for review/approval by the Employer for necessary reference which includes the following:

- a) System overview document

- b) Cross Reference Document
- c) Functional design document
- d) Standard design documents
- e) Design document for customisation
- f) System Administration documents- software utilities, diagnostic programs etc.
- g) Software description documents
- h) Bill of Quantity & List of software and hardware deliverable
- i) protocol implementation documents
- j) point address document
- k) IP addressing plan document
- l) Software User document for dispatchers
- m) Software Maintenance document
- n) Training documents
- o) Database settings, Displays and Reports to be implemented in the system
- p) Test procedures
- q) Test reports
- r) Hardware description documents
- s) Hardware User documents
- t) Hardware Maintenance documents
- u) Data Requirement Sheet (DRS) of all Hardware
- v) Site specific Layout, Installation, GA, BOQ, schematics and cabling details drawings/documents
- w) RT-DAS & IT Integration Plan Document using XML & other nterfaces.
- x) Cyber Security Plan document & certificate/report
- y) Interoperability profiles/ Tables

After approval two sets of all the above documents as final documents shall be delivered to site by the Contractor. In case some modifications/corrections are carried out at site, the contractor shall again submit as built site specific drawings in three sets after incorporating all such corrections as noticed during commissioning. Any software modifications/updates made at site shall also be documented and submitted in three sets to site and one set to Employer.

In addition to paper copies, two sets of final documentation shall be supplied on Electronic media to employer. The contractor shall also submit two sets of the standard documentation of Operating system and Databases in electronic media. Paper copies of these may be submitted, if the same are available from the OEM as a standard part of delivery. One copy of the software packages used for accessing & editing the final documentation in electronic media shall also be provided.

After successful completion of System availability test, the contractor shall take the software backup of complete RT-DAS system on electronic media and two copies of these backup software shall be submitted to the owner.

This section describes the project management, schedule, quality assurance, and documentation requirements for the project.

7.1 Project Management

The Contractor shall assign a project manager with the authority to make commitments and decisions that are binding on the Contractor. Employer will designate a project manager to coordinate all employer project activities. All communications between employer and the Contractor shall be coordinated through the project managers. The project managers shall also be responsible for all communications between other members of the project staffs.

Bidder shall submit the manpower deployment plan along with the bids, describing the key roles of each persons.

8.6 Project Schedule

The project implementation schedule shall be not exceed 18 months from the date of award. Based upon this schedule the bidder shall submit a preliminary implementation plan along with the bid. The detail project implementation schedule shall be submitted by the contractor after award for employer's approval, which shall include at least the following activities:

- (a) Site Survey
Documents submission and approval schedule
- (b) Factory & Site Testing Schedule
- (c) Database development schedule
- (d) Hardware purchase & Manufacturing, Software development & integration schedule
- (e) Despatch Schedule
- (f) Installation / commissioning schedule
- (g) Training schedule

The project schedule shall include the estimated period for completion of and its linkage with other activities.

8.7 Quality Assurance & Testing

All materials and parts of the system / sub-system to be supplied under the project shall be of current manufacture from a supplier regularly engaged in the production of such equipment.

8.7.1 Quality Assurance and Quality Control Program

A Quality Assurance Program of the Contractor shall generally cover but not be limited to the following:

- a. The organization structure for the management and implementation of the proposed Quality Assurance Program.
- b. Documentation control system.
- c. Qualification data for key personnel.
- d. The procedure for purchase of materials, parts/components and

- selection of sub-contractor's services including vendor analysis, source inspection, incoming raw material inspection, verification of material purchases, etc.
- e. System for shop manufacturing including process controls.
 - f. Control of non-conforming items and system for corrective action.
 - g. Control of calibration and testing of measuring and testing equipments.
 - h. Inspection and test procedure for manufacture.
 - i. System for indication and appraisal of inspection status.
 - j. System for quality audits.
 - k. System for authorizing release of manufactured product to utility.
 - l. System for maintenance of records.
 - m. System for handling, storage and delivery.
 - n. A Quality Plan detailing out the specific quality control procedure adopted for controlling the quality characteristics of the product.

The Quality Plan shall be mutually discussed and approved by the employer after incorporating necessary corrections by the Contractor as may be required.

Neither the enforcement of QA/QC procedures nor the correction of work mandated by those procedures shall be cause for an excusable delay.

The scope of the duties of the employer, pursuant to the Contract, will include but not be limited to the following:

- (a) Review of all the Contractor's drawings, engineering data etc.
- (b) Witness or authorize his representative to witness tests at the manufacturer's works or at site, or at any place where work is performed under the Contract.
- (c) Inspect, accept or reject any equipment, material and work under the Contract in accordance with the specifications.
- (d) Issue certificate of acceptance and/or progressive payment and final payment certificate
- (e) Review and suggest modification and improvement in completion schedules from time to time; and
- (f) Monitor the Quality Assurance program implementation at all stages of the works.

8.7.2 Inspection

The Contractor shall give the employer/Inspector one week in case of domestic supplies and four weeks in case of foreign supplies written notice of any material being ready for testing. Such tests shall be to the Contractor's account except for the expenses of the Inspector. The employer/Inspector, unless witnessing of the tests is waived, will attend such tests on the scheduled date for which employer/Inspector has been so notified or on a mutually agreed alternative date. If employer/Inspector fails to attend the testing on the mutually agreed date, Contractor may proceed with the test which shall be deemed to have been made in the Inspector's presence and Contractor shall forthwith forward to the Inspector, duly certified copies of the test results in triplicate.

8.7.3 Inspection and Test

The test shall be considered complete when (a) when all variances have been resolved (b) all the test records have been submitted (c) Employer acknowledges in writing the successful completion of the test.

8.7.3.1 Test Plans & Procedures

Test plans for both factory and field tests shall be provided by the Contractor to ensure that each test is comprehensive and verifies all the features of the equipment are tested. The test plans for factory and field tests shall be submitted for Employer approval before the start of testing.

The contractor shall prepare detail testing procedure in line to specification and submit for employer's approval. The procedure shall be modular to the extent possible, which shall facilitate the completion of the testing in the least possible time.

8.7.3.2 Test Records

The complete record of all factory and field acceptance tests results shall be maintained by the Contractor. The records shall be maintained in a logical form and shall contain all the relevant information. The test reports shall be signed by the testing engineer and the engineer witnessing the tests.

8.7.3.3 Reporting of variances

A variance report shall be prepared by either Employer or Contractor personnel each time a deviation from specification requirements is detected during inspection or testing. All such variances shall be closed in mutually agreed manner.

However, at any stage if employer feels that quality of variances calls for suspension of the testing the testing shall be halted till satisfactory resolution of variances, which may involve retesting also.

Chapter 9

A) DESIGN PARAMETERS AND PERFORMANCE TABLES

The RT-DAS system shall be designed as per the technical parameters defined in the specification and the tables specified here. The RT-DAS system (such as databases, network elements etc.) shall be sized to accommodate the requirement mentioned in table 7.

The system shall be tested with the doubled present power system size (ultimate capacity) as defined in table 6& measure the various performance of the system as defined in the tables and technical specification including peak and average load scenarios.

The auxiliary memory utilisation , average CPU, RAM & LAN utilisation parameters shall not exceed the limits as defined in table 8. This memory utilisation includes the memory used for storage of data for the defined duration as specified in the various sections of technical specification.

The RT-DAS system shall be suitable for addition of atleast double the operator workstations (in future) without requiring any up gradation of the servers.

The RT-DAS design & performance parameters are defined in the following tables:

TABLE 1 - DESIGN PARAMETERS FOR RT-DAS FUNCTIONS

TABLE 2 - DESIGN PARAMETERS FOR ISR FUNCTIONS

TABLE 3 - MAINTENANCE ACTIVITIES

TABLE 4- DESIGN PARAMETERS FOR USER INTERFACE

TABLE 5 - CONFIGURATION CHARACTERISTICS & AVAILABILITY FUNCTIONS

TABLE 6 - POWER SYSTEM SIZE

TABLE 7- OTHER PERFORMANCE REQUIREMENTS

TABLE 8 - ACTIVITIES FOR NORMAL AND PEAK LEVEL OF LOADING

TABLE 1 – DESIGN PARAMETERS FOR RT-DAS FUNCTIONS

Note ; The parameters which are not indicated in the tables & only mentioned elsewhere in the specification shall also be considered as design parameters

Ref. Section	Function Description	Design capacity	Execution rate
-------------------------	-----------------------------	------------------------	-----------------------

Ref. Section	Function Description	Design capacity	Execution rate
<u>2.3.1</u>	Data Acquisition from FRTU	As per specification	
	a) Status data	All status points	<ul style="list-style-type: none"> ▪ By exception, updated & displayed within 4sec from data collection from FRTU at S/s 6 sec from data collection from FRTU ▪ Integrity check of all status at every 10 Minutes (configurable) ▪ On demand ▪
	b) Analog data	All analog points	<ul style="list-style-type: none"> ▪ By exception, updated & displayed within 5 sec & 10sec ▪ Integrity check for all analog at every 10 Minutes (configurable) ▪ provision for all analog update at periodicity of 10 sec configurable upto 1 hour. ▪ Energy values periodically configurable from 5 min to 24 hours ▪ On demand <p>The time skew at RT-DAS control centre ,S/S , RMU,FPI shall not be more than 0.1sec at each location & latency shall not be more than 0.5sec for status. For analog data the time skew shall not be more than 1sec & latency shall not be more than 1sec for analog as per IEEE C37.1.</p> <p>Energy values of 15 minute blocks shall be collected periodically from the RTU, FRTU at scan rate of 15 minute/1 hour (configurable upto 24 hours). Alternatively, the energy values shall be calculated for each 15 minute/1 hour blocks at RT-DAS level from the acquired energy values of MFTs through RTU & FRTU.</p>

Ref. Section	Function Description	Design capacity	Execution rate
<u>2.3.2</u>	Time synchronisation of RTU	All FRTUs shall be synchronised from Master station	every 5 Minutes (Configurable from 5-60 minutes)
<u>2.3.3</u>	RT-DAS Data Exchange with other system as specified (R-APDRP system)	As per specification	A/R for ISR function & data exchange
<u>2.3.4</u>	Data Processing		
	Analog data processing:		
	a) Conversion to engineering units	Per analog points	Each time the value is received in RT-DAS
	b) Zero dead band processing	Per analog points	Each time the value is received in RT-DAS
	c) Reasonability Limit checking	High and Low reasonability limits per analog point	Each time the value is received in RT-DAS
	d) Limit Monitoring	High and Low for each of the limits per analog point	Each time the value is received in RT-DAS
	e) RATE OF CHANGE	per analog point	Each time the value is received in RT-DAS
	Digital Input data processing	As per specification	As per specification
	Substation Topology Processing	For no. of status, refer FRTU point counts in the technical specification. within 1 sec response after updation in RT-DAS database	Triggered by status change.
	Quality codes	As per specification	Each time value is received by RT-DAS
2.3.5	Sequence-of-Events data	1000 events circular buffer in the RT-DAS database	SOE retrieval Periodically (5 minutes) or by exception and On demand
<u>2.3.6</u>	Failsoft capability	Critical functions	in the event of system crosses mark of peak loading requirements through graceful degradation of non - critical functions & also relaxing periodicity / update rate of display refresh & critical functions by 50%..

TABLE 2 – DESIGN PARAMETERS FOR ISR FUNCTIONS

Reference section	Function Description	Design capacity	Execution rate	Response time
2.3.8	SAIFI SAIDI Table feeders, substation, town, Discom , state shall be generated automatically and maintained indicating planned , unplanned and total value of SAIFI	Double present count	Daily, weekly, query based , Monthly, Quarterly, Yearly, FY	2 sec after updation in RT-DAS database
			b) 2 months retention	
	SOE table	a) Volume of data = Total telemetered points and max/min with time stamp and average for each analog point with quality code	a) Hourly	
		b) data storage On Auxiliary memory	b) 2 months retention	
	Daily Energy data table	Volume of data = Export/Import KWh & Export/Import KVARh for all energy meters with quality code	a) Energy values of 15 minute blocks of each Hour	
		b) data storage On Auxiliary memory	b) 2 months retention	
	SOE data table	daily 4 changes per SOE point	Each time the SOE is received from RTU/FRTU/FPI in RT-DAS database	
	System message Log Storage	a) 20,000 entries /month		
		b) data storage On Auxiliary memory	b) 2 months retention	

Table - 4

Maintenance activities

Action	Performance
Complete database regeneration	2 hours
Complete system software build, including operating system, applications, and databases	6 hours
Software build of all applications and databases	3 hours
Software build of a single applications and databases	10 minutes
Installation of a single, new display including distribution to all consoles	60 seconds
Reinstallation of all displays	60 minutes
Perform an on-line update of a database parameter and propagation of the change to the source data	60 seconds

TABLE 5 - DESIGN PARAMETERS FOR USER INTERFACE

Reference section	Name	Design capacity	Execution rate
3.1-3.3	SYSTEM ACCESS SECURITY Function and Data Access Security Operating jurisdictions	16	
3.4	Windows Environment		
	Rooms	32	
	Layers	8	
	Declutter Levels	16	
	Panning and Zooming	supported	
3.7	TREND		
	a) Trend files	10	
	b) Variables per trend file	4	
	c) Samples per trend variable	5,000	
	d) Sampling rate	Configurable from 5 sec to 15 minutes	
3.8			Triggered by event
	Alarm priority levels	16	

Reference section	Name	Design capacity	Execution rate
	Alarm Message Recording on auxiliary memory - alarms	2months	
3.9	EVENTS Event Message Recording on Auxiliary memory - events	2months	

TABLE 6 - CONFIGURATION CHARACTERISTICS & AVAILABILITY FUNCTIONS

Reference Section	Name	Execution Rate	Maximum Response Time (With in)
6	CONFIGURATION CHARACTERISTICS AND AVAILABILITY Backup Databases Data backup	60 seconds or event driven	5 seconds
	Processor Errors Processor failure detection		10 seconds
	Device Errors Device failure detection		10 seconds
	Processor Redundancy and Configuration Management Function Restart Other functions except ISR ISR		30 seconds 120 seconds
	Processor Start-Up <i>with applications functional</i> 1) Hot Start 2) Warm Start a) all applications 3) Cold Start a) Application except ISR operational b) ISR application		1) Not more than failover time 2) 10 minutes a) 15 minutes 3) 15 minutes a) 20 Minutes b) 60 Minutes
	Device/Processor Failover		30 seconds from detection of failure

Table 8- PERFORMANCE REQUIREMENTS

(a) USER INTERFACE REQUIREMENTS

At no time the RT-DAS system shall delay the acceptance of User request or lockout console operations due to the processing of application functions.

User interface requirements	Response time (Peak loading)
Requests for call-up of displays shall be acknowledged with an indication of request is being processed	Within 2 sec
Any real time display and application display (except RDBMS DB displays) on workstation console, Complete display & data values shall appear on screen	Within 3 sec after acknowledgement of request
Manual Data entry of the new value shall appear on screen	Within 2 sec
Display update rate	Every 2 sec for at least 4 displays together
Panning of a world display from one end of screen to other end of screen in a continuous manner	Within 2sec
Alarm and event response time	display within 1 sec of receipt in RT-DAS system
Alarm and event acknowledgement	With in 2 sec
Requests for printing of displays shall be acknowledged with an indication of request is being processed	Within 2 sec
Requests for generation of reports shall be acknowledged with an indication of request is being processed	Within 2 sec

(b) UTILISATION

(Considering double the present power system size)

Name	Average Utilization	Comments
PROCESSOR UTILIZATION		
Servers	30%	Normal loading
	50%	Peak loading
Front end PROCESSOR	30%	Normal Loading
	67%	Peak loading
Main memory utilisation (avg)	50%	Normal loading
	67%	Peak loading
Auxiliary memory utilisation	50%	

Table 8- ACTIVITIES FOR NORMAL AND PEAK LEVEL OF LOADING

(1) NORMAL LEVEL OF ACTIVITY

The normal level of activity shall simulate system activities spread over one hour period. During the testing, the response times and the average utilizations shall not exceed the specified values. The following conditions define normal level of system activity to generate the normal loading scenario. Test simulation shall be done using software tool to generate this loading within 1 hr. Staggering of loads during the test duration of 1 hour is permitted.

- (a) All FRTU data shall be scanned and processed as specified in the Specification.
- (b) All data exchange with other systems shall occur as specified in the Specification.
- (c) All periodic functions shall be executed at the rates defined in tables
- (d) The following RT-DAS functions shall be executed on-demand:
- (e) Alarms (2 X no. of FRTU+) per hour shall be generated. Each alarm shall be acknowledged individually within 5 seconds
- (f) Events (2 X no. FRTU) per hour shall be generated.
- (g) 1% analog of total analog/ 5sec measurements of total analog point count changes as per IEEE C37.1
- (h) One complete run of on-line diagnostics shall be performed on all computers
- (i) Communications channel monitoring shall be performed.
- (j) The following user interface actions shall be performed:

Display Selection	20 per operator workstation
Display Updates	Each operator workstation shall display 3 updating and 1 non-updating display window per monitor. This also includes VPS. Updating displays: - alarm summary list - world display containing a S/S SLD - Network display
Data Entry	5 data entry actions from any single display
Display Trending	8 display trends, each trending 4 variables
Reports	Prepare and printing of 5 reports

- (k) The following maintenance activities shall be performed:

Function	Task
On-Line Database Editing	Modify 20 data points in each of the 5 FRTUs
Display Generator and Management	Modify one single-line diagram one tabular display

2) PEAK LEVEL OF ACTIVITY

The peak level of activity is an addition to the average level of activity described in (A) NORMAL LEVEL OF ACTIVITY above. The peak level of activity shall be applied for a five minute period. During the next ten minutes, only the normal level of system activity shall be applied. This test shall be repeated for four consecutive fifteen minute periods, for a total peak level test time of one hour. The five-minute peak loading period shall coincide with RT-DAS system period where all periodic software is scheduled for execution and at least one five minute period shall span an hour boundary to consider the scheduled hourly periodic activities. There shall be no restrictions on the period when the five-minute peak can occur.

The software execution rates and response times defined in tables of this section , shall not be degraded and the utilization defined in tables of this section shall not exceed during the peak loading conditions. The following conditions shall define the additional peak level of system activity:

- (a) As per IEEE C37.1
 - a. 15 % of status of total status points/ 5sec measurements
 - b. 40% analog of total analog measurements /5sec

50% of the alarms shall be acknowledged within the five-minute period (automatic acknowledgement is unacceptable).

- (c) Display Requests
 - 6 display requests per minute per console

- (f) Reports
 - Prepare 5 reports.

Chapter 10
A) BILL OF QUANTITY

RT-DAS at Data centre (BoQ)

S.No.	Equipment	Unit	Quantity
A1	Server/ workstation Hardware		
1.	RT-DAS server	No.	2
2.	FEP server with interface switches	No.	2
3.	ISR server	No.	2
4.	Developmental server with console	No.	1
5.	Workstation with dual TFT Monitors	No.	4
	Switches		
6.	Layer II switch	No.	2
7.	Router one each for interfacing IT system & MPLS network	No.	A/R
8.	GPS Time synchronisation system	Set	2
9.	Any other item to meet specification requirements		
A2	Software		
10.	RT-DAS software	Lot	1
11.	ISR Software	Lot	1
12.	Any other item to meet specification requirements	Lot	A/R

UTILITY SHALL ATTACH RT-DAS CONFIGURATION DIAGRAM

B) BILL OF QUANTITY

FRTU (Town wise, Circle wise, DISCOM wise)

S.No.	Equipment	Unit	Quantity
C1	FRTUs		
1.	FRTU comprising panels, racks, sub-racks, Power Supply modules, CPU analog / digital input module as per specification interfacing equipment, required converters & all other required items/accessories including complete wiring for all modules for locations mentioned below	Set	1/ss
2.	MFTs	No.	As per I/O
3.	CMRs	No.	As per I/O
4.	Router/ modem	No.	Per S/S A/R
5.	Any other hardware to meet functional /performance requirement of MTS	Lot	A/R
C2	TEST EQUIPMENTS for RTU		
6.	FRTU Database Configuration & Maintenance Software tool & Master Station cum RTU Simulator & Protocol analyser software tool & Laptop PC for above software tools along with interfacing hardware including Hub	No.	1 /circle

TILTY SHALL FRTU CONNECTIVITY DIAGRAM

C) FRTU Pointcount

SNO	STATION	SS	MFT	Com module	DI module
	TOTAL				

Note: - SS : Single status input, Relay, METER : Energy meter, CM: Communication Module , DI : Digital input ,

- Note:**
1. MFT provide data that is to be acquired by fRTU on Modbus/or IEC protocol for Voltage (phase to phase and phase to neutral), Current (phase and neutral), Active Power, Reactive Power, Apparent Power, Power Factor, Frequency, active energy (import & export), reactive energy (import & export) etc.
 2. CMRs shall be mounted in the existing C&R panels. Wherever the space is not available in the existing panels the same shall be mounted in the FRTU panels
 3. The FRTU shall be equipped for the above specified I/O (analog input MFT), digital input) point points, which includes 20 % spare for future use . These 20 % spare points shall be terminated on terminal blocks in FRTU panel.
 4. All protection relay/Alarm points & CBs shall be considered for SOE.
 5. Point counts include three alarms per station for auxiliary system and fire, which shall be interfaced to FRTU.

D) Auxiliary Power supply

S.No.	Item	Unit	Quantity
F5	For FRTU		
1.	DC Power Supply (DCPS) system based on SMPS	No	1/RTU
2.	Battery bank for above DCPS (VRLA Type) for minimum 4 hrs backup		

Power supply at DC to be ensured by utility for uninterrupted supply

A/R : As required as per site requirements

Provide Equipment break-up at each location

UTILITY SHALL ATTACH COMMUNICATION NETWORK DIAGRAM FOR ALL PROPOSED MODES

F) IMPLEMENTATION SCHEDULE

S. No.	Items	Completion Schedule from the Award of Contract
1	RT-DAS System	As per IPDS guidelines

BIDDER SHALL PROVIDE IMPLEMENTATION SCHEDULE INDICATING MILESTONES